

Labfors 5

Bench-Top Bioreactor - Version for Solid Substrates and Enzymatic Bioprocesses



INFORS HT
Headoffice, Switzerland

Rittergasse 27
CH-4103 Bottmingen
T +41 (0)61 425 77 00
F +41 (0)61 425 77 01
info@infors-ht.com
service@infors-ht.com

INFORS HT, Germany
Dachauer Str. 6
D-85254 Einsbach
T +49 (0)8135 8333
F +49 (0)8135 8320
infors.de@infors-ht.com

INFORS HT, UK
The Courtyard Business Centre
Dovers Farm, Lonesome Lane,
Reigate
Surrey, RH2 7QT, UK
T +44 (0)1737 22 31 00
F +44 (0)1737 24 72 13
infors.uk@infors-ht.com

INFORS HT, France
2, rue du Buisson aux Fraises
Bâtiment D13
F-91300 Massy
T +33 (0)1 69 30 95 04
F +33 (0)1 69 30 95 05
infors.fr@infors-ht.com

INFORS HT, Benelux
Markweg 9-A, NL-6883 JL
Velp (GLD)
P.O. Box 125, NL-6880 AC
Velp (GLD)
T +31 (0)26 369 31 00
F +31 (0)26 369 31 09
infors.bnl@infors-ht.com

INFORS HT, USA
9070 Junction Drive, Suite D
Annapolis Junction, MD20701
T +1 301 362 3710 /
T +1 855 520 7277 (toll-free USA)
F +1 301 362 3570
infors.usa@infors-ht.com

INFORS HT, Canada
8350 rue Bombardier
Anjou, Quebec
Canada H1J 1A6
T +1 514 352 5095
F +1 514 352 5610
infors.ca@infors-ht.com

INFORS HT, China
Room 503, C Hall,
M8 Office Building
No. 1 Jiuxianqiao East Road
Chaoyang District, Beijing
China 100015
T +86 10 51652068
F +86 10 64390585
info@infors-ht.com.cn

INFORS HT Southeast Asia
16, 1st Floor, Taman City
MY-51200 Kuala Lumpur
Malaysia
T +603 625 771 81
F +603 625 067 48
info@infors-ht.com.my

INFORS HT, South America
Rua Dr. Alceu de Campos
Conjunto 205
CEP: 04544-000
São Paulo – SP
Brasil
T +55 (11) 95304-0201
F +55 (11) 98585-5334
infors.br@infors-ht.com

**Contact details of our local dealers worldwide can be found
on our website.**

www.infors-ht.com



Engineering and production in Switzerland

Table of Contents

1 General Information 8

1.1 About this Manual 8

1.2 Explanation of Special Notices 9

 1.2.1 Warning Notices 9

 1.2.2 Other Notices..... 9

1.3 Device Identification (Standard Identification Plate).... 10

1.4 Declaration of Conformity 10

1.5 Customer Service and Services 10

2 Safety and Responsibility 11

2.1 Intended Use, Incorrect Use and Misuse 11

2.2 Qualified Personnel 12

 2.2.1 Provider 12

 2.2.2 User 12

 2.2.3 Operator 13

2.3 Unauthorised Persons 14

2.4 Responsibility of the Provider 14

2.5 General Hazards..... 15

 2.5.1 Electrical Current..... 15

 2.5.2 Unauthorised Spare Parts and Accessories 15

2.6 Particular Hazards 15

 2.6.1 Hot Surfaces..... 16

 2.6.2 Dangerous Gases 16

 2.6.3 Flammable or Explosive Substances 16

 2.6.4 Corrosive or Toxic Substances 16

 2.6.5 Bioactive Substances or Pathogenic Organisms 17

 2.6.6 Overpressure or Vacuum 17

2.7 Warning Symbols on the Device..... 17

2.8 Declaration of Decontamination..... 18

3 Setup and Function..... 19

3.1 Basic Unit..... 19

 3.1.1 Power Switch..... 20

 3.1.2 Pumps 21

 3.1.3 Identification Plate 22

 3.1.4 Mains Connection and Device Fuses..... 22

 3.1.5 Water Connections 22

 3.1.6 Gas Connections 23

 3.1.7 Signal Connections 24

 3.1.8 Connections for Vessel 25

 3.1.9 Gassing Connection (Sparger/Head Space) 26

Table of Contents

- 3.1.10 Sensor Connections (Sensor Cables)26
- 3.1.11 Connections Exit Gas Cooler and Valve for Water Flow.....27
- 3.2 Operating Panel28
 - 3.2.1 Monitor Keys.....28
 - 3.2.2 Operating Panel Connections.....29
- 3.3 Culture Vessel.....30
 - 3.3.1 Top Plate31
 - 3.3.2 Ports in the Vessel Top Plate and their Configuration31
- 3.4 Temperature Control System.....32
- 3.5 Stirrer33
- 3.6 Gassing System36
- 3.7 Exit Gas.....37
- 3.8 pH Control37
- 3.9 pO₂ Control.....39
- 3.10 Antifoam Control41
- 4 Options42**
 - 4.1 Pump(s).....42
 - 4.2 Balances42
 - 4.3 Exit Gas Analysis43
 - 4.3.1 Measurement Systems (Gas Sensors).....43
 - 4.3.2 Connecting the Gas Sensors.....43
 - 4.3.3 Calibration.....44
 - 4.3.4 Replacing the BlueVary Gas Sensor Cartridge45
 - 4.4 Multiplexer (Gas Switching Module)45
 - 4.5 Permissive Measurement45
 - 4.6 Conductivity Measurement46
 - 4.7 Pressure Control47
- 5 Accessories50**
 - 5.1 Base Tray51
 - 5.2 Reagent Bottle and Pump Holder51
 - 5.3 Sampling System Super Safe Sampler.....52
 - 5.4 Sparger with Sterile Sheath56
 - 5.5 Impellers.....58
 - 5.6 Immersion Pocket for Temperature Sensor (Pt100) ...58
 - 5.7 Blanking Plugs58
 - 5.8 Addition Port Adapters60
 - 5.9 Inoculation Needles.....60
 - 5.10 Septum Collars.....63
 - 5.11 Probe Protection for pH Sensor64

Table of Contents

5.12 Dip Tubes 65

5.13 Clamping Adapters 67

5.14 Sensor Holder 68

5.15 Threaded Adapter 69

5.16 Adapter 69

5.17 Exit Gas Cooler 70

5.18 Reagent Bottles 72

5.19 Antifoam Sensor 74

5.20 Pump Heads 75

5.21 Sterile Filters 75

5.22 O-Rings and Gaskets 77

5.23 Hoses and Accessories 77

5.24 Inoculation Accessories and Tools 78

6 Transport and Storage 79

6.1 Transport 79

6.2 Storage 80

7 Installation and Commissioning 81

7.1 General Location Requirements for Installation 81

7.2 Minimum Distances 82

7.3 Power Supply 82

7.4 Water Supply and Return 82

7.5 Gas Supply 83

7.6 Exit Gas 84

7.7 Test Run 84

7.7.1 Preparation Test Run 84

7.7.2 Filling the Water Circuit 87

7.7.3 Stirring 87

7.7.4 Heating and Adjusting Temperature 88

7.7.5 Gassing 88

7.7.6 End of Test 88

8 Before Cultivation 90

8.1 Preparing and Autoclaving the Culture Vessel 90

8.1.1 Mounting the Glass Vessel in the Holder 91

8.1.2 Checking Gaskets (O-Rings) 93

8.1.3 Mounting the Impellers 94

8.1.4 Assembling and Mounting the Sparger 95

8.1.5 Moistening/Filling the Culture Vessel 97

8.1.6 Fitting the Vessel Top Plate 98

8.1.7 Mounting a Threaded Adapter 100

8.1.8 Mounting the Blanking Plugs 100

Table of Contents

8.1.9	Mounting Addition Port Adapters.....	102
8.1.10	Mounting the Immersion Pocket for Temperature Sensor (Pt100).....	103
8.1.11	Preparing an Inoculation Needle	103
8.1.12	Equipping Port with Septum Collar and Septum for Inoculation.....	104
8.1.13	Mounting the Exit Gas Cooler.....	105
8.1.14	Checking Lubrication of the Mechanical Seal	107
8.1.15	Preparing the Sensors.....	107
	8.1.15.1 Calibrating the pH Sensor	108
	8.1.15.2 Fitting a pH Sensor with a Probe Protection	109
	8.1.15.3 Mounting Sensors with Sensor Holder	110
8.1.16	Preparing the Super Safe Sampler.....	112
8.1.17	Mounting the Sparger Hose and the Inlet Air Filter	114
8.1.18	Mounting the Hose and Inlet Air Filter for Head Space Gassing.....	115
8.1.19	Preparing the Gassing Hose Line on the Basic Unit	115
8.1.20	Calibrating the Pumps	116
8.1.21	Preparing the Reagent Bottles, Pumps and Hoses.....	116
8.1.22	Sterile Hose Connections	119
8.1.23	Removing the Pump Heads.....	119
8.1.24	Checklist Before Autoclaving.....	121
8.1.25	Autoclaving	122
8.2	Connecting the Culture Vessel and Preparing the Cultivation	124
8.2.1	Connecting the Culture Vessel.....	124
8.2.2	Mounting the Pump Heads	125
8.2.3	Filling the Reagent Hoses	125
8.2.4	Connecting the Gassing	126
8.2.5	Connecting the Exit Gas Cooler	127
8.2.6	Coupling the Motor	128
8.2.7	Filling the Culture Vessel.....	129
8.2.8	Inserting the Temperature Sensor (Pt100) into the Immersion Pocket.....	130
8.2.9	Connecting the pH Sensor	131
8.2.10	Connecting the pO ₂ Sensor.....	132
8.2.11	pO ₂ Sensor (Analogue, Polarographic) Polarisation	133
8.2.12	Calibrating the pO ₂ Sensor	133

Table of Contents

	8.2.13 Checking the Hoses and Hose Connections	133
9	Cultivation.....	134
9.1	Preparing the Medium	134
9.2	Sampling	135
9.3	Inoculation.....	138
9.3.1	Inoculation with Inoculation Needle.....	139
9.3.2	Inoculation with a Syringe	140
9.3.3	Inoculation Using Dip Tube / Addition Port Adapter	140
9.4	Extending the Sparger with the Sterile Sheath.....	141
9.5	Harvest.....	141
9.6	Emptying the Culture Vessel	142
9.7	Emptying the Reagent Hoses	142
9.8	Switching off the Device	143
9.9	Autoclaving the Culture Vessel after Cultivation.....	144
10	Cleaning and Maintenance.....	146
10.1	Cleaning Agent and Disinfectant	146
10.2	Cleaning the Culture Vessel - Routine Cleaning	146
10.3	Removing the Vessel Top Plate and Accessories.....	148
10.3.1	Removing the Exit Gas Cooler	148
10.3.2	Removing the Sensors	149
10.3.3	Removing Hoses, Filters and Pump Heads	150
10.3.4	Removing Blanking Plugs	151
10.3.5	Removing Threaded Adapters	152
10.3.6	Removing the Inoculation Needle, Septum Collar and Septum.....	152
10.3.7	Removing Addition Port Adapters	152
10.3.8	Removing the Vessel Top Plate	153
10.3.9	Removing the Immersion Pocket for Temperature Sensor (Pt100).....	154
10.3.10	Removing the Sparger and the Dip Tube(s)	154
10.3.11	Removing the Impellers.....	156
10.3.12	Removing the Stirrer Shaft	156
10.4	Removing the Glass Vessel from the Holder.....	157
10.5	Cleaning and Storing Individual Parts	159
10.6	Cleaning the Sensors	161
10.7	Cleaning the Hoses and Pump Heads	161
10.8	Cleaning the Super Safe Sampler	161
10.9	Cleaning the Basic Unit and Operating Panel	162
10.10	Maintenance Plan	162

Table of Contents

10.11	Lubricating the Mechanical Seal	164
10.12	Decalcifying the Device	165
10.13	Decalcifying the Device via Vessel Jacket.....	166
11	Interferences	168
11.1	Interferences Basic Unit and Operating Panel.....	168
11.2	Interferences Drive System.....	169
11.3	Interferences Temperature Control System.....	170
11.4	Interferences Gassing System.....	170
11.5	Interferences pH-System	172
11.6	Interferences pO ₂ System	174
11.7	Interferences Feed and Pump	175
11.8	Replacing Device Fuses	175
11.9	Behaviour in Case of Power Interruption	176
11.10	Returning for Repair.....	176
12	Disassembly and Disposal	177
12.1	Disassembly.....	177
12.2	Disposal	178
13	Technical Data	179
13.1	Dimensions 1 Unit.....	179
13.2	Dimensions Master Unit and Satellite Units.....	181
13.3	Dimensions of Culture Vessels in Vessel Holder.....	182
13.4	Weights (net).....	184
13.5	Connection Values	184
13.5.1	Electrical	184
13.5.2	Water IN.....	184
13.5.3	Water OUT.....	185
13.5.4	Gas(es) IN	185
13.5.5	Exit Gas	185
13.6	Specifications	186
13.6.1	Operating Panel.....	186
13.6.2	Culture Vessel	186
13.6.3	Stirrer	187
13.6.4	Temperature Control System	190
13.6.5	Gassing.....	190
13.6.6	Antifoam Control	191
13.6.7	pH Control.....	191
13.6.8	pO ₂ Control	192
13.6.9	Pumps.....	193
13.7	Operating Conditions	193
13.8	Emissions.....	194

Table of Contents

13.9 Utilities	194
13.10 Auxiliary Supplies	194
14 EC-Declaration of Conformity.....	195

General Information

1 General Information

1.1 About this Manual

This manual enables the safe and efficient handling of the device.

All the information and instructions in this operating manual comply with the current standards, legal regulations, the latest technological and scientific developments and the knowledge gained from the manufacturer's many years of experience in this field.



This operating manual is a component part of the device. It must be kept near to the device and must be accessible to the operators at all times.

The users must read the operating manual thoroughly and fully understand its contents before beginning any work.

Adhering to all the safety and operating instructions in this manual is essential to ensure that work is carried out safely.

The scope of delivery may differ from the explanations, descriptions and figures in this operating manual due to special designs, additional options specified on ordering and the latest technical/mechanical modifications.

This manual contains illustrations to aid general understanding. These may differ from the actual device as supplied.

1.2 Explanation of Special Notices

1.2.1 Warning Notices

Warning notices in this manual are indicated by a coloured bar and begin with a signal word that signifies the degree of the hazard.

WARNING

The signal word “WARNING” indicates a potentially dangerous situation that may result in severe or even fatal injuries if not avoided.

CAUTION

The signal word “CAUTION” indicates a potentially dangerous situation that may result in minor injuries if not avoided.

1.2.2 Other Notices

ATTENTION

The word “ATTENTION” on a blue bar indicates a situation that may result in significant damage to property if not avoided.

INFORMATION

Texts located below a grey bar bearing the notice “INFORMATION” provide useful tips and recommendations for ensuring efficient, fault-free operation of the device.

General Information

1.3 Device Identification (Standard Identification Plate)

The identification plate is designed to allow clear identification of the device. It contains the following information:

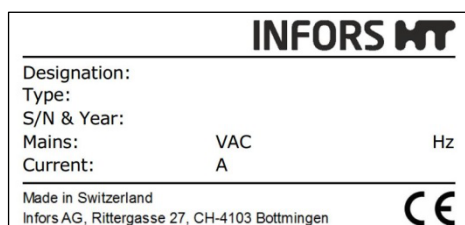

- Manufacturer name
- Designation = Category of device
- Type = Device type (name)
- S/N = Serial number
- Year = Year of manufacture
- Mains = Nominal voltage and frequency
- Current = Current consumption
- Manufacturer address
- CE marking

1.4 Declaration of Conformity

The device is in compliance with the essential requirements of the following Directives:

- Directive 2006/42/EC on Machinery
- EMC Directive 2014/30/EU

The Declaration of Conformity according to Directive 2006/42/EC on Machinery, annex II 1 A is attached to the operating manual, refer to chapter “EC-Declaration of Conformity”.

1.5 Customer Service and Services

Our Customer Service is at your disposal for technical advice and specialist enquiries. For contact information, see page 2.

Due to their familiarity with the potential applications of the device, the Customer Service team is able to provide information on whether the device can be used for a specific application or modified to handle the planned process.

Furthermore, our colleagues are always interested in new information and experiences resulting from user’s applications for the device that may be valuable for the continued development of our products.

2 Safety and Responsibility

This section describes general considerations relating to user safety that must be taken into account when working with the device.

In the remaining sections, warning notices are used only to highlight particular hazards directly arising from the actions being described in the section in question.



It is essential to read the operating manual carefully – especially this section and the warning notices in the text – and to follow the instructions therein.

This section also refers to areas that are the responsibility of the provider due to certain risks arising from particular applications for which the device is used deliberately and with full awareness of the associated risks.

2.1 Intended Use, Incorrect Use and Misuse

The bench-top bioreactor Labfors 5 from INFORS HT is designed especially for running bio processes with microorganisms or animal cells for research and development in a biotechnology laboratory.

The device is designed and constructed exclusively for the intended use described above.

Intended use also includes following all the instructions in this operating manual, especially those relating to:

- The installation site
- User qualifications
- Correct operation and maintenance
- The use of undamaged tubing and glass vessels

Any failure to observe the requirements specified in this manual shall be deemed incorrect use.

Any use of the device outside the scope of the intended use as described above shall be deemed misuse.

This also applies to applications for which the device is not designed, such as the use or production of explosive gases, which is not permitted because the device is not explosion-proof.

Safety and Responsibility

For use for special applications not covered by conventional, intended use, the device must be modified and certified accordingly by the manufacturer.

Any use of the device outside of a biotechnology laboratory, i.e. in any environment in which the conditions required for the safety of the users cannot be fulfilled or cannot be fulfilled to their full extent, shall also be deemed misuse.

2.2 Qualified Personnel

Due to the complexity of the device and the potential risks arising from its operation, the device may only be used by qualified, specialist personnel.

2.2.1 Provider

The term “provider” applies to all persons who are responsible for making the device and the necessary infrastructure available. These persons may also be included in the group of people known as “users”, though this is not always the case.

Irrespective of whether a provider is a member of the company’s board of management or a supervisor, they bear a special level of responsibility with regard to the processes and the qualification and safety of the users.

2.2.2 User

General

The term “user” applies to all persons who come into contact with the device in any way and perform work on or with it. This primarily applies to the following activities, which can be performed by the manufacturer’s own specialists or a variety of other persons (it is not always possible to distinguish clearly between the different types of person):

- Assembly, installation and commissioning
- Definition and preparation of the process
- Operation
- Troubleshooting and remedying of faults
- Maintenance and cleaning (autoclaving, if necessary)
- Service work and repairs
- Disassembly, disposal and recycling

Safety and Responsibility

Qualified personnel

On account of their specific education, training and – in many cases – experience, the qualified personnel required for this work are able to recognise risks and respond accordingly to potential hazards.

The qualified personnel (either internal or external) who cannot be categorised under the separate “operators” group are made up of the following groups of persons:

- Electricians (electrical engineers)
- Decontamination specialists
- Repair specialists
- Specialists in disassembly and (environmentally friendly) disposal
- Recycling specialists

2.2.3 Operator

The “operators” are a specific sub-group of users distinguished by the fact that they work with the device. They are the true target audience for this operating manual.

Qualified technicians

Only technicians who have been trained for working in a biotechnology laboratory can be considered for the role of operator. These include:

- Process technicians in the fields of biotechnology and chemistry
- Biotechnologists (biotechnicians)
- Chemists with a specialisation in biochemistry; chemists in the field of organic chemistry or biochemistry
- Life scientists (biologists) with special education in cytology, bacteriology, molecular biology, genetics, etc.
- Lab assistants (lab technicians) from various fields

In order to be classed as a “sufficiently qualified technician” for the operation of the device, the persons in question must have received thorough training and have read and understood the operating manual.

The operator must be informed in a training session provided by the provider of the tasks delegated to the operator and the potential risks of improper conduct. Tasks that go beyond the scope of operation under normal conditions may only be performed by the

Safety and Responsibility

operator if this is specified in the manual and the provider has explicitly entrusted said tasks to the operator.

Technicians in training

Persons in this group who are undergoing training or apprenticeships are only permitted to use the device under supervision and in accordance with the instructions of a trained and qualified technician.

2.3 Unauthorised Persons

The term “unauthorised persons” applies to all persons who can access the work area but are not qualified to use the device in accordance with the aforementioned requirements.

Unauthorised persons are not permitted to operate the device or use it in any other way.

2.4 Responsibility of the Provider

The device is used for industrial and scientific purposes. As such, the provider of the device is individually liable with regard to the legal requirements relating to occupational health and safety in a biotechnology laboratory. In particular:

- The provider is responsible for ensuring that the work and environmental regulations applicable in a biotechnology laboratory are observed.
- The provider must ensure that the device remains in safe and proper working condition throughout its entire term of use.
- The provider must ensure that all safety equipment is fully functional and is not disabled.
- The provider must ensure that the device is only worked on by qualified users, and that said users receive sufficient training.
- The provider must ensure that the protective equipment required for working with the device is provided and worn.
- The provider must ensure that this operating manual remains in the immediate vicinity of the device throughout its entire term of use.

2.5 General Hazards

This section covers general hazards and residual risks that are always present when using the device in accordance with normal, intended use.

The following notices are general in nature. As such, with a few exceptions they are not repeated in the remaining sections.

2.5.1 Electrical Current



The device runs on electrical power. There is an immediate risk of fatal injury if contact is made with live parts.

The following points must be observed in order to avoid the risk of fatal injury:

- In case of damage to insulation, disconnect the device from the power supply immediately and arrange for it to be repaired.
- Disconnect the device from the power supply before commencing any work on the electrical system.
- Always use qualified electricians for any work on the electrical system.
- Keep moisture away from live parts. It may lead to a short circuit.

2.5.2 Unauthorised Spare Parts and Accessories



Incorrect or imitated spare parts and accessories as well as spare parts or accessories that have not been authorised by the manufacturer represent a significant safety risk. As such, we recommend procuring all spare parts and accessories from an authorised dealer or directly from the manufacturer. For the contact details of the manufacturer's representatives, see page 2.

2.6 Particular Hazards

This section covers particular hazards and residual risks that may arise when using the device for special applications in accordance with normal, intended use.

Since the use of the device for such applications is deliberate, it is the responsibility of the operators and the provider to ensure that all personnel are protected from potential damage to health. The

Safety and Responsibility

provider is responsible for ensuring that the appropriate protective equipment for such applications is provided, and that the necessary infrastructure is in place.

2.6.1 Hot Surfaces



For processes that are carried out with temperatures over 55 °C, there is a danger of burns on hot surfaces.

Since the device is intended for applications at high temperatures, it is the responsibility of the users to ensure that they have sufficient protection.

The motor gets hot during operation. There is a risk of burns if it is touched.

2.6.2 Dangerous Gases



The use or production of dangerous gases i.e. toxic or asphyxiant gases entails a significant health risk, especially in enclosed spaces.

In order to prevent high emissions of dangerous gases, the following measures must be taken:

- The gas connections on the device must be checked before any cultivation processes using dangerous gases are initiated.
- The gaskets on the device must be checked at regular intervals and replaced if necessary.
- Siphon off exit gas safely.

2.6.3 Flammable or Explosive Substances



The use or production of flammable or explosive substances is not covered under “intended use” of the device, as the device is not explosion-proof.

If the provider intends to use the device for such purposes, he must check its suitability for the planned application with the responsible local authorities.

2.6.4 Corrosive or Toxic Substances



The use or production of corrosive or toxic substances entails a significant health risk. As such, special measures must be taken to protect the users for such applications.

Safety and Responsibility

Since the device is used deliberately for such applications, it is the responsibility of the users to ensure that they have sufficient protection.

2.6.5 Bioactive Substances or Pathogenic Organisms



The use or production of bioactive substances, pathogenic organisms or genetically modified cultures entails a significant health risk. As such, special measures must be taken to protect the users for such applications.

Since the device is used deliberately for such applications, it is the responsibility of the users to ensure that they have sufficient protection.

2.6.6 Overpressure or Vacuum



Glass vessels may break or shatter when subjected to overpressure or vacuums.

2.7 Warning Symbols on the Device

The following warning symbols (stickers) are attached to the device:

Position

- Motor



WARNING

Illegible or missing warning symbols on the device will lead to the user being exposed to risks that the warning symbols in question were designed to make him or her aware of.

It is the provider's responsibility to ensure that all the stickers with warning symbols on the device are always intact.

Safety and Responsibility

2.8 Declaration of Decontamination

When returning the device for repair, disassembly or disposal, it is required for the safety of all parties involved and because of legal provisions that a lawful declaration of decontamination is present.

The following must be observed if this is the case:

- The device, the component part or accessory must be entirely decontaminated before sending to the manufacturer
- The provider is therefore required to completely and truthfully fill out a declaration of decontamination, and have it signed by the person responsible.
- **The declaration of decontamination must be affixed on the outer packaging in which the device is sent back.**
- These forms can be obtained from the licensed dealer or the manufacturer. See address on page 2.

Important notice

If the return shipment is not accompanied by a signed and complete declaration of decontamination or it is not affixed to the outer packaging, the shipment will be returned unopened to the sender at their expense (see also T&C).

3 Setup and Function

3.1 Basic Unit

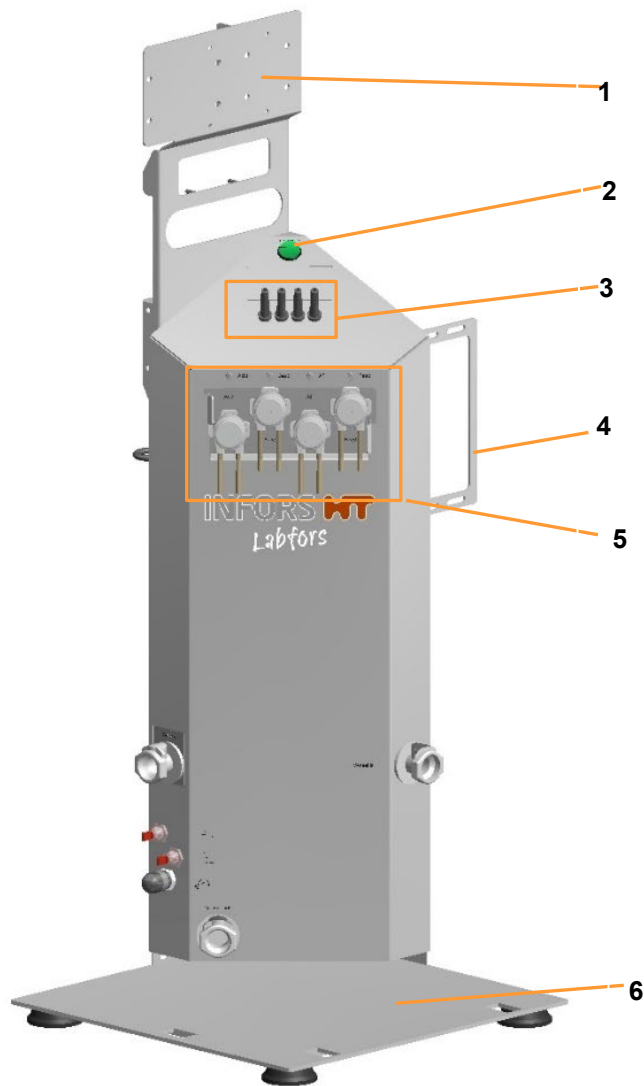

- | | | | |
|---|--|---|--|
| 1 | Holder for operating panel, manometers and pressure reduction valves | 4 | Holder for gassing unit(s) ¹⁾ and optional pressure control |
| 2 | Power switch | 5 | Pumps |
| 3 | Sensor cables | 6 | Base plate |

¹⁾ depending on the chosen gassing strategy this can be rotameter(s), mass flow controller(s), solenoid valve(s)

Setup and Function

The whole measurement and control technology of the bioreactor is integrated in the basic unit. One operating panel with touch-screen software can be used to control up to six bioreactors (culture vessels) see also chapter “Operating Panel”. This means, one basic unit serves as the master unit and can control up to five more basic units, referred to as satellite units.

3.1.1 Power Switch



The power switch, a green rocker switch, is located on top of the basic unit. It is labelled with **POWER** and lights up as soon as the device is switched on. In addition to normal switching on and off, the power switch also serves as an emergency switch.



INFORMATION

In the event of an emergency shutdown via the power switch during a running bioprocess, all settings are saved. After switching on via the power switch, the bioprocess continues with the same settings as before the emergency shutdown. This is also the case if the bioprocess is controlled via eve®, the platform software for bioprocesses.

3.1.2 Pumps

Corrective reagent and feed solutions are added via four peristaltic pumps. The pumps are driven by stepper motors.

The drive shafts of the pumps are situated on the upper front side of the console on the basic unit. Direction of rotation is clockwise by default. Rocker switches for manual operation of the pumps are provided above the drive shafts. They are labelled as follows (from left to right):

- **Acid**
- **Base**
- **AF (Antifoam)**
- **Feed**

When the basic unit is switched on, pumps can be manually operated via the rocker switches:

- Push and hold the rocker switch to the left:
The pump drive shaft turns counter clockwise
- Push and hold the rocker switch to the right:
The pump drive shaft turns clockwise.

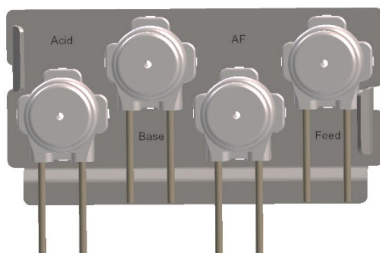
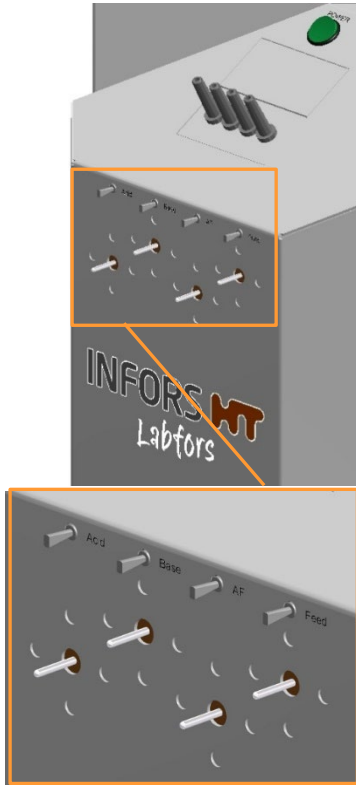

The autoclavable pump heads are latched onto a mounting plate. The mounting plate is identically as the drive shafts labelled with the pump names.

The pump heads together with the mounting plate can easily be plugged onto or pulled off the drive shafts.

A transparent, not autoclavable (!) cover plate made of plexiglass (highlighted in red in the picture on the left) can be inserted into the holder of the mounting plate for protection during operation.

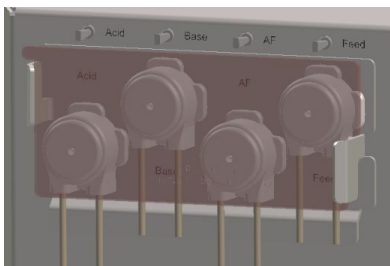

Setup and Function

3.1.3 Identification Plate

The identification plate is located on the rear of the basic unit.

The data provided on the identification plate is specified in the main chapter “General Information”, chapter “Device Identification”.

3.1.4 Mains Connection and Device Fuses

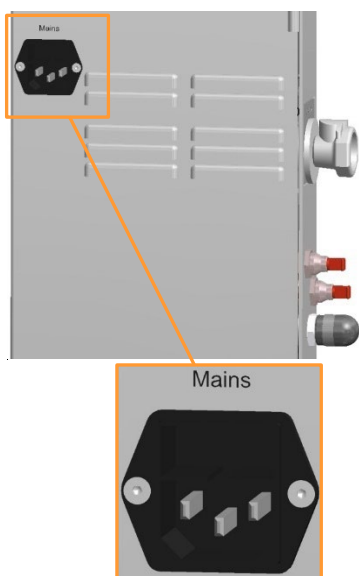

The mains connection is located on the rear side of the basic unit. It is labelled with **Mains**.

The device is protected against excessive current consumption by two fuses. The device fuses are located directly above the mains connection.

The country-specific power cable required for connection to the power supply is included in the scope of delivery. If the power cable is defective, replace it with a power cable of the same type.

Before connecting the device, make sure that the voltage values of the device correspond to the local mains voltage. The mains connection must be easily accessible at all times so that the device can be disconnected from the power supply quickly in case of an emergency.

3.1.5 Water Connections

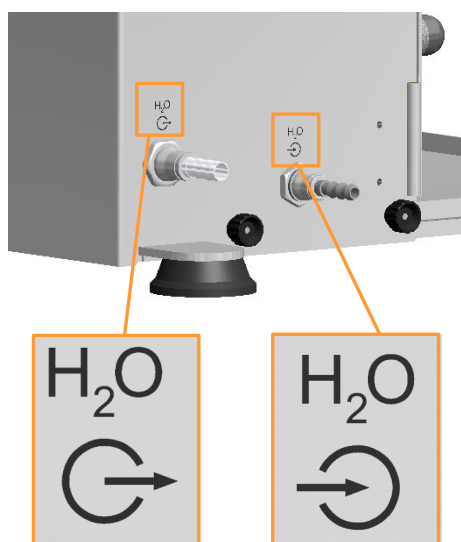

The two hose nozzles for connection of water inlet and outlet of the basic unit are situated on the rear side at the bottom of the console. They are labelled with corresponding symbols:

- Left: Water outlet
- Right: Water inlet

3.1.6 Gas Connections



The gas connections are located at the top rear of the basic unit and are labelled with the corresponding gas. Each gas connection has a check valve, manometer and pressure reducing valve. The number of connections varies depending on the configuration.

The factory settings of a pressure reducing valve must not be changed!

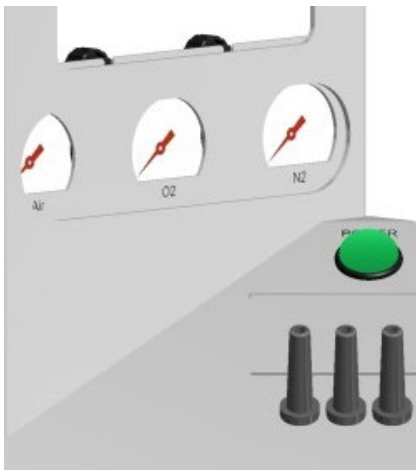

On the front of the device, the manometers are also clearly labelled with the corresponding gas.

Setup and Function

3.1.7 Signal Connections

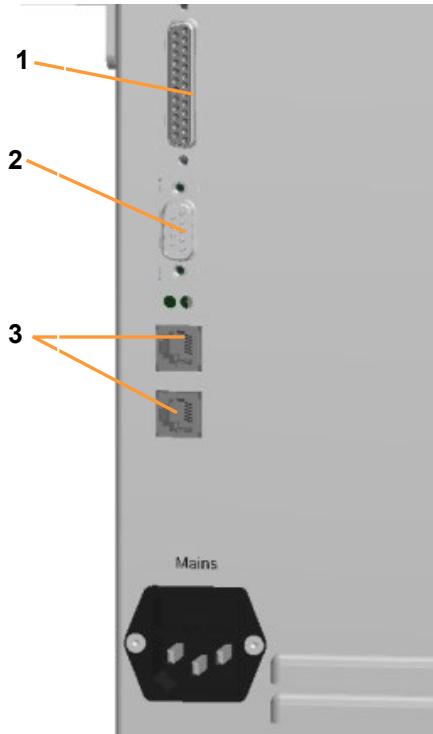

The following signal connectors are situated above the mains socket (from top to bottom):

- 1 25 pin Dsub Multi I/O: for connecting analogue and digital input and output signals (0/4..20 mA)
- 2 9 pin RS232: for connecting a balance or a switchbox with up to 7 balances
- 3 2 x iDDC bus: for connecting the touch screen operating unit and one or two satellites

3.1.8 Connections for Vessel

The water connectors for the vessel jacket are labelled with corresponding symbols.

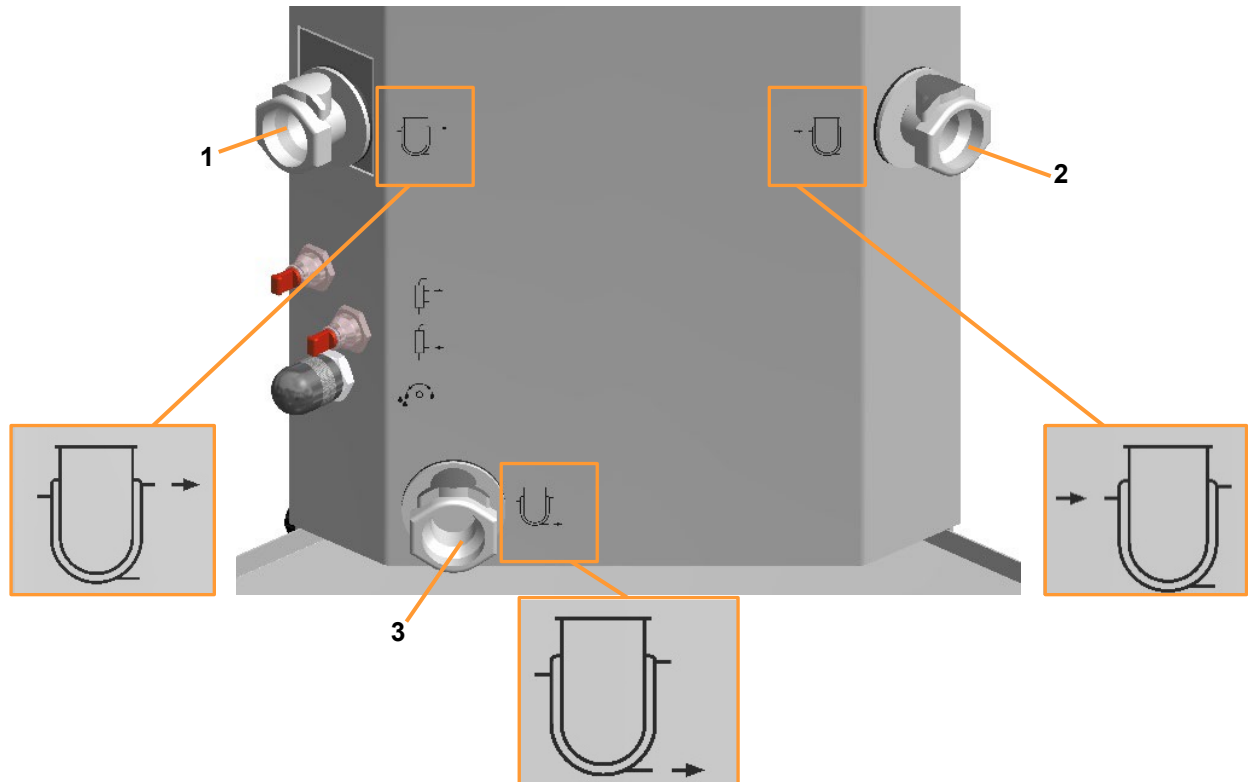

- 1 Water overflow vessel jacket
- 2 Water inlet vessel jacket

- 3 Water outlet vessel jacket

Setup and Function

3.1.9 Gassing Connection (Sparger/Head Space)

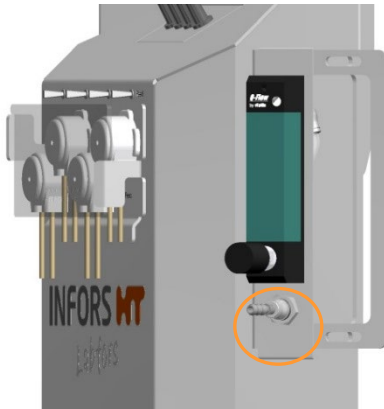

The hose nozzle for connection of the gassing hose (sparger or head space gassing) is located below the holder for gassing unit ¹⁾ on the right side of the basic unit.

¹⁾ depending on the chosen gassing strategy, this can be rotameter(s) or mass flow controller(s)

3.1.10 Sensor Connections (Sensor Cables)

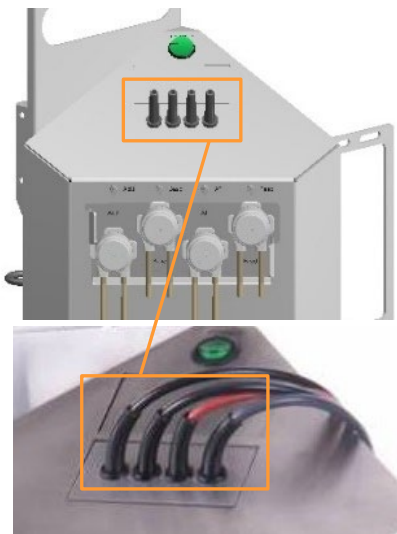

The basic unit is equipped and configured by default for measurement of temperature, pH, pO₂ and for foam detection (“antifoam”). This means, the temperature sensor (Pt100) and the cables for connecting the pH, pO₂ and antifoam sensors are always present. The appropriate sensors are separately available, they are not included in the standard package.

From left to right: pH / Antifoam / Temperature (Pt100) / pO₂.

i INFORMATION

Depending on the chosen variant, the measuring system for pH and pO₂ is equipped and configured either for analogue or digital sensors from the manufacturer METTLER or digital sensors from the manufacturer HAMILTON.

3.1.11 Connections Exit Gas Cooler and Valve for Water Flow

The water connections for the (optional!) exit gas cooler and the manual valve for the water flow regulation are located on the left front side of the basic unit. The connectors are closed with plugs and the valve is covered with a cap on delivery. Connections and valve are labelled with symbols.

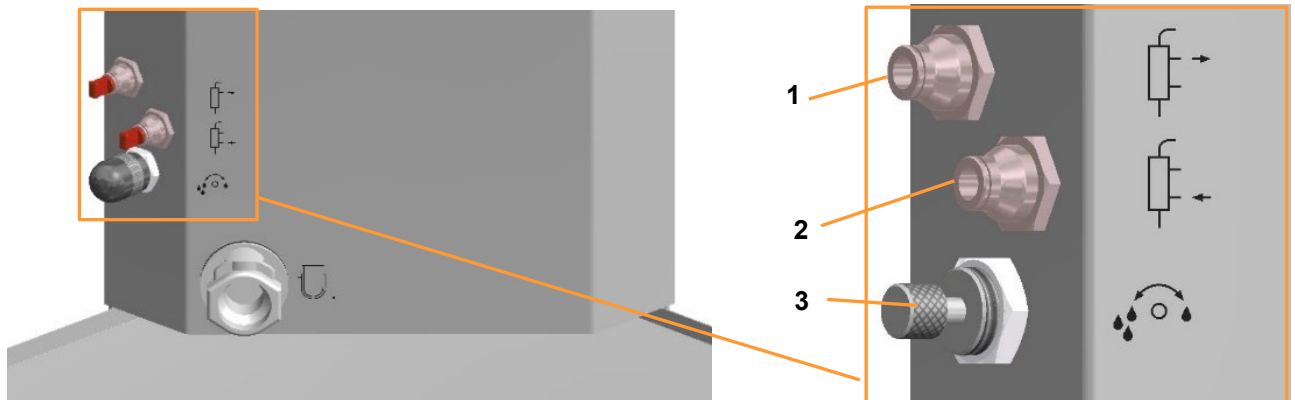

- 1 Water outlet exit gas cooler
- 2 Water inlet exit gas cooler

- 3 Water flow regulation

The valve is factory adjusted. If needed, water flow can be manually adjusted here. A counter nut is provided to lock the valve in its desired position.

Setup and Function

3.2 Operating Panel



The operating panel has a 12" colour-touch screen with protection IP66.

Up to six bioreactors (= culture vessels) can be individually or in parallel controlled by one operating panel.

A detailed description of the touch screen software can be found in the separate manual.

3.2.1 Monitor Keys

Four monitor keys are situated on the upper left side of the touch screen operating panel.

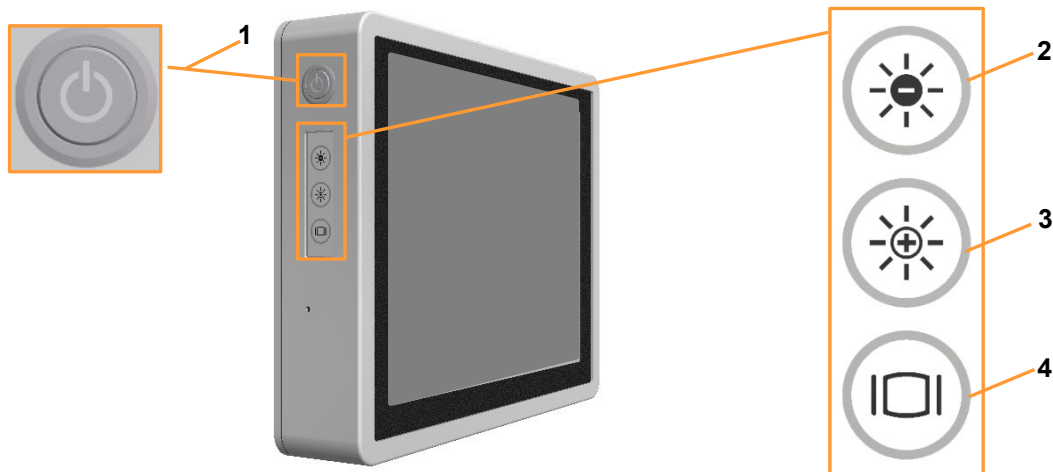

- | | |
|--|---|
| <p>1 ON/OFF key</p> <p>2 DECREASE brightness key: to set the display illumination darker</p> | <p>3 INCREASE brightness key: to set the display illumination brighter</p> <p>4 DISPLAY key: to switch the display on/off</p> |
|--|---|

Special details about the ON/OFF key

The touch screen operating panel is switched on and off at the main switch on the instrumentation cabinet. Therefore, separate switching on at the **ON/OFF** key is not necessary. The symbol on the key is illuminated when the operating panel is switched on.

Switching the operating panel off during a running process is the equivalent to a power failure!

3.2.2 Operating Panel Connections

Six connectors labelled with different symbols are situated on the rear side of the operating panel.

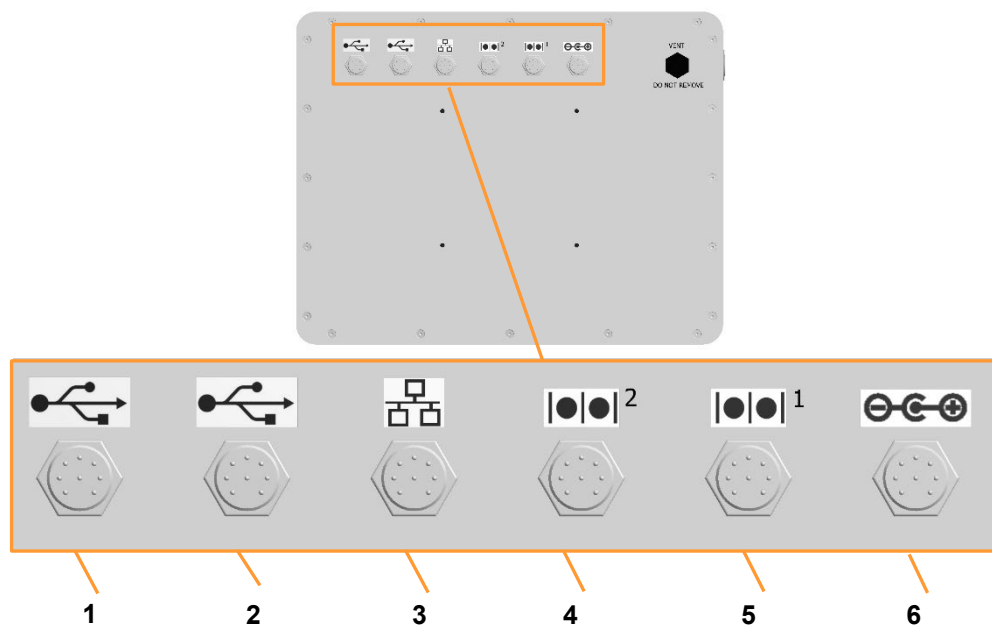

- | | | | |
|---|--|---|--|
| 1 | USB2.0 x 2: for backups and service purposes ¹⁾ | 4 | COM2 (Reserve) |
| 2 | USB2.0 x 2: (Reserve) | 5 | COM1: for display cable ¹⁾ |
| 3 | Ethernet: for Ethernet cable ¹⁾ to connect with a network | 6 | DC: for power supply cable ¹⁾ |

¹⁾ Cable supplied with device

Setup and Function

3.3 Culture Vessel

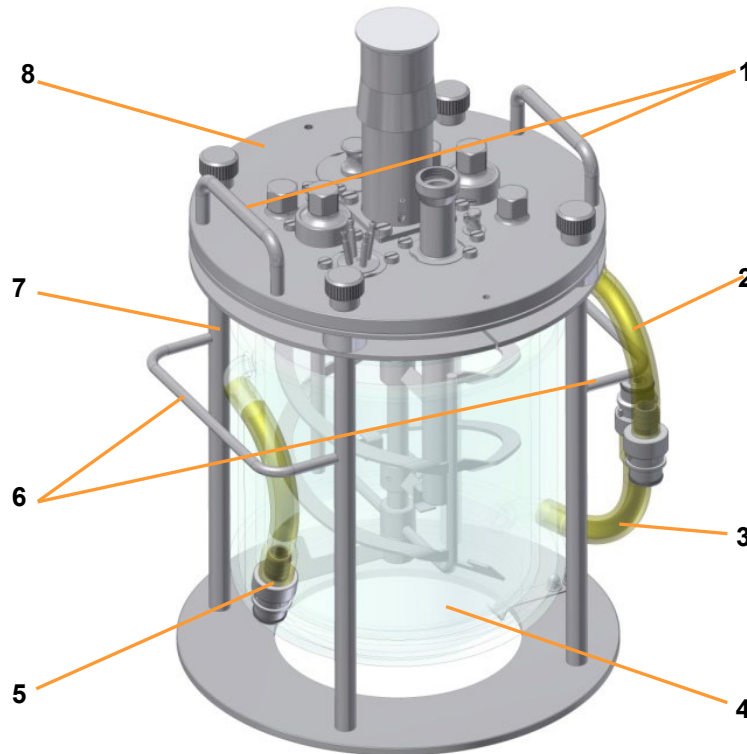

- | | | | |
|---|------------------------------|---|---------------------------|
| 1 | Handhold top plate | 5 | Water inlet vessel jacket |
| 2 | Water overflow vessel jacket | 6 | Handhold vessel holder |
| 3 | Water outlet vessel jacket | 7 | Vessel holder |
| 4 | Glass vessel | 8 | Top plate |

The culture vessel consists of the glass vessel, the top plate with standard mounting parts and handholds and the vessel holder with handholds. The vessel has a flat bottom and is made of double walled borosilicate glass. It is supplied with pre-fitted silicon hoses and rapid couplings for connection to the basic unit.

The vessel holder has two side handles, which are used when emptying and cleaning the vessel or transporting it to the autoclave. They also serve as safety bars for the glass hose connections on the water connections. There are two additional handles on the top plate.

3.3.1 Top Plate

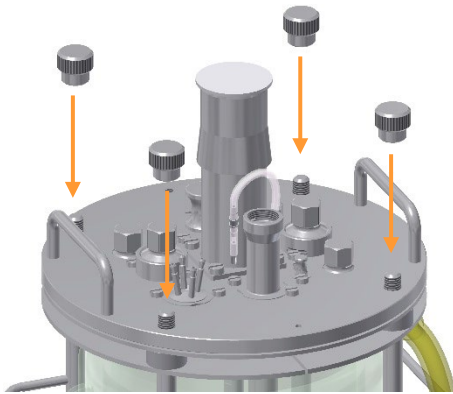

Four knurled nuts are used to fixate the top plate to the glass vessel and the vessel holder. Drive hub and motor coupling are located in the middle of the vessel top plate.

3.3.2 Ports in the Vessel Top Plate and their Configuration

The vessel top plate has different ports of different sizes to mount the different components such as sparger, blanking plugs, sensors etc.

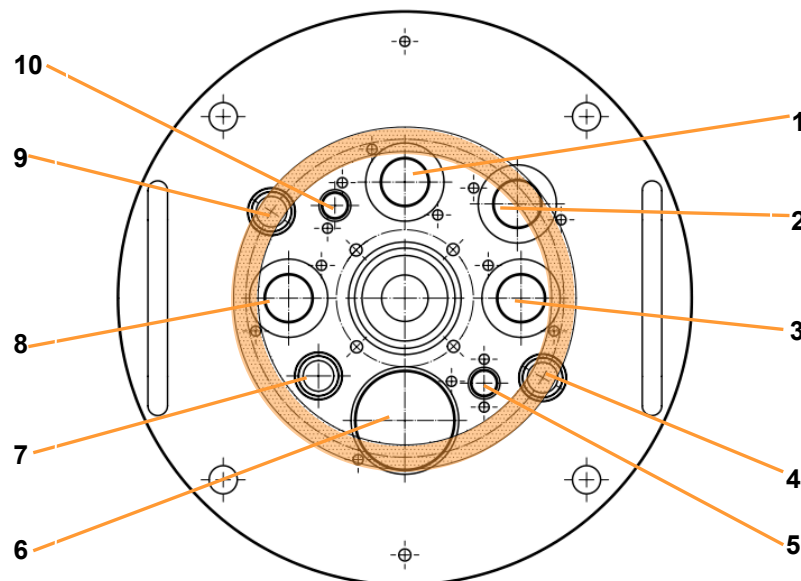

- | | | | |
|---|---|----|--|
| 1 | Ø 19 mm: Ø 19 mm: pH sensor with probe protection | 6 | Ø 40 mm: addition of solids |
| 2 | Ø 19 mm: addition port adapter, quadruple | 7 | Ø 12 mm / Pg13.5: pO ₂ sensor |
| 3 | Ø 19 mm: sparger | 8 | Ø 19 mm: sampling |
| 4 | Ø 12 mm / Pg13.5: inoculation needle | 9 | Ø 12 mm / Pg13.5: exit gas cooler |
| 5 | Ø 10 mm: spare | 10 | Ø 10 mm: immersion pocket temperature sensor (Pt100) |

Setup and Function



INFORMATION

The area highlighted in orange in the figure above represents the radius of the helix impellers. Long built-in-parts such as e.g. dip tubes in the ports with numbers 2, 4 and 9 may collide with the rotating helix impeller.

Check that impellers do not collide with any built-in-part after mounting by manually rotating the stirrer.

3.4 Temperature Control System

The temperature control takes place in the vessel jacket, which is connected to the basic unit. For heating, water is heated by means of an electrical heating element in the basic unit. Cold water is fed into the circuit for cooling. The overflow in this open system prevents a dangerous overpressure in the circuit and allows pressure equalisation of the vessel jacket during sterilisation in the autoclave.

Measurement of the temperature in the culture vessel takes place by a platinum resistance sensor (Pt100). Water flow is regulated via solenoid valve.

3.5 Stirrer

Overview

The stirrer shaft is rotated counter-clockwise (top view) by a top drive.

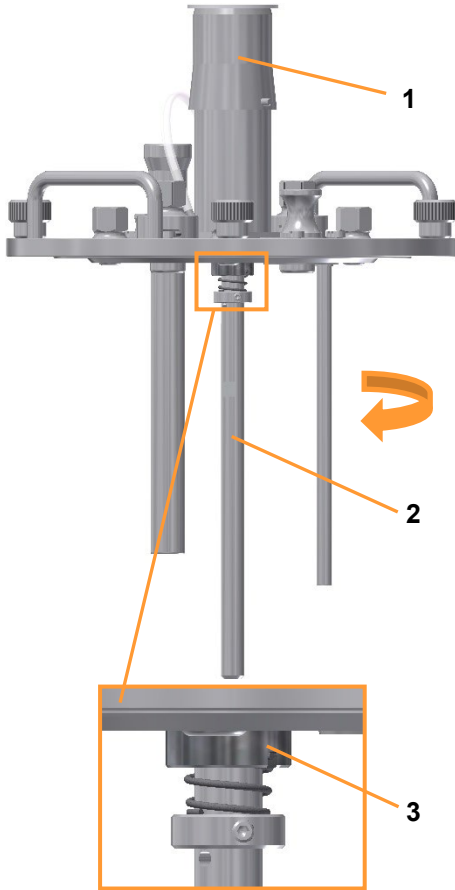

- 1 Drive hub
- 2 Stirrer shaft
- 3 Mechanical seal

The stirrer shaft is screwed on the drive hub in the vessel top plate and is sealed by a single mechanical seal.



ATTENTION

Manipulation on the mechanical seal may lead to its damage!

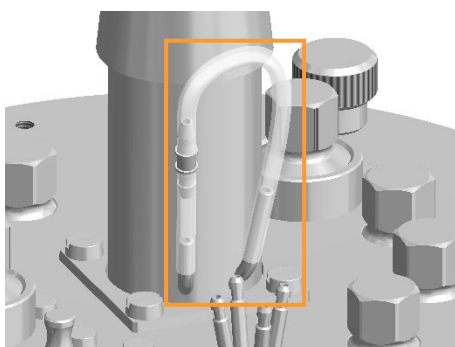

The mechanical seal must be lubricated at any time. For this, two nozzles fitted with a piece of silicone hose are located on the drive hub.

For details see chapter "Lubricating the Mechanical Seal" in the main chapter "Cleaning & Maintenance".

Setup and Function

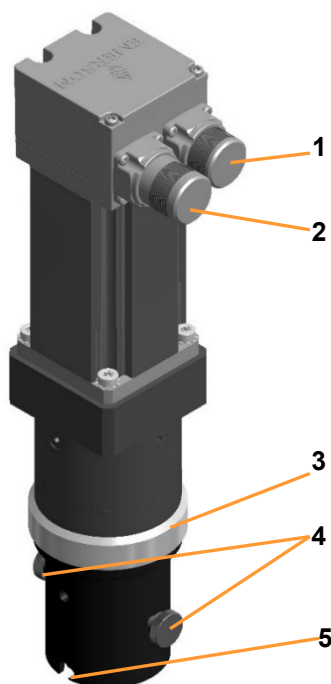

Motor

A servo motor with 3:1 transmission with a high torque is used.

- 1 Signal connection for (orange) signal cable
- 2 Power connection for (green) power cable
- 3 Gear ratio 3 : 1
- 4 Fixing screws
- 5 Bayonet lock

The motor has a mechanic coupling and is coupled to the drive hub on the top plate.



The servomotor is operated by a separate AC servo amplifier. This is connected to the basic unit via two cables (not visible in the picture to the left). The power cable (green) and the signal cable (orange) are connected on the rear side of the amplifier box. Control of the servomotor takes place via touch screen operating panel.

Stirrer speed

Depending on the cultivation phase and the impellers used, lower or higher speeds are used. The maximum adjustable stirrer speed can be limited to 300 min^{-1} by the user in the touch screen software, if required. For details on the specifications, see the main chapter "Technical Data", "Specifications", "Stirrer".

Use in a 115-V electricity grid

The servomotor requires a voltage of 230 V and must therefore only be connected to a 230-V connection. If the motor is to be operated in a 115-V electricity grid, a transformer can be connected between the power connection and the servo amplifier. This converts the grid voltage of 115 V into a voltage of 230 V and uses this to power the servomotor.

Impellers

Different models can be used and combined. All impellers listed below are supplied as standard. They are all affixed to the stirrer shaft by means of grub screws.

- Pitched blade impeller (45°)

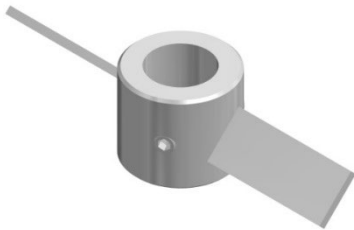

- Fork blade impeller

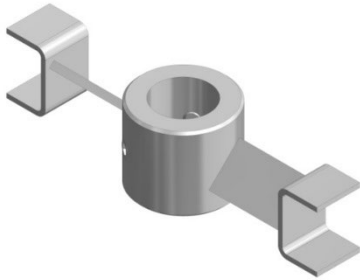

- Anchor impeller

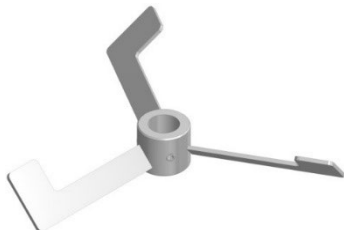

- Single helix impeller



Setup and Function

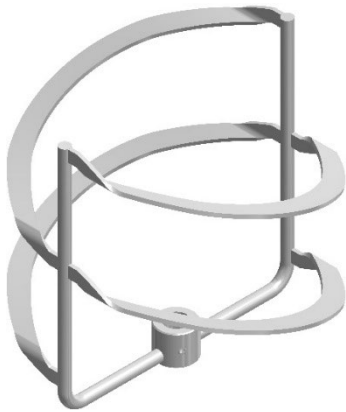

- Double helix impeller

3.6 Gassing System

The basic unit is equipped with the appropriate gassing units (rotameter or mass flow controllers) and configured according to the chosen gassing strategy.

The following gases can be used:

- Air
- Nitrogen (N₂)

Gas mix system

The gas mixture takes place before entry into the culture vessel. The composition of the gas mixture is set and controlled in the touch screen software.

A detailed description of the touch screen software can be found in the separate manual.

Gas entry

The gas or the gas mixture is led via a silicone hose from the gassing connection on the basic unit to the culture vessel. The gas entry either takes places by head space or sparger gassing:

- For head space gassing, the gas is led via addition port adapter into the head room of the culture vessel, i.e. above the culture medium.
- For sparger gassing, the gas is led directly via optional sparger into the medium in the culture vessel. To prevent the sparger from becoming clogged due to solid substances in the medium, the sparger is protected by means of a sterile sleeve.

3.7 Exit Gas

Pressure in the culture vessel may be increased due to temperature increase or gas production also without actively gassing the culture. For this reason, installing an exit gas line to the vessel is mandatory for every cultivation process.

Deviating the exit gas without exit gas cooler

If no exit gas cooler is used, the exit gas can be deviated via addition port adapter or inoculation needle fitted with an exit gas filter.

However, using this method may lead to blocking the exit gas filter due to humidity in the exit gas. For this reason, the use of an exit gas cooler is strongly recommended.

The exit gas cooler is separately available, it is NOT included in the standard package.

Deviating the exit gas via exit gas cooler

The exit gas cooler dries the exit gas by condensation so that humidity cannot block the exit filter. This prevents from liquid loss in the culture medium at the same time.



INFORMATION

If strong build-up of foam is expected, a foam trap i.e. a bottle containing antifoam agent can be installed before the exit gas filter as an additional safety precaution.

For details see main chapter “Accessories”, chapter “Exit Gas Cooler”.

3.8 pH Control

Function

The pH value in the medium is measured by the pH sensor and controlled by addition of reagents (acid, base). Addition of acid and base takes place via the two peristaltic pumps *Acid* and *Base*.

Reagent bottles are filled with acid and base which are connected to an/the addition port adapter(s) in the vessel top plate and the two pumps by silicone hoses.

Measurement system

Depending on the variant selected, the measurement system for pH is equipped and configured for analogue or digital sensors

Setup and Function

manufactured by METTLER or digital sensors manufactured by HAMILTON.

Measurement system variants	Properties
METTLER analog	<ul style="list-style-type: none"> Conventional pH sensor (potential measurement against reference) Type: 405-DPAS-SC-K8S/120
METTLER digital	<ul style="list-style-type: none"> Conventional pH sensor (potential measurement against reference) with built-in electronics Type: InPro 3253i, ISM
HAMILTON digital	<ul style="list-style-type: none"> Conventional pH sensor (potential measurement against reference) with built-in electronics Type: Easyferm Plus ARC

INFORMATION

pH sensors type Easyferm Plus ARC are preconfigured by the device manufacturer INFORS HT. Replacement sensors must be configured before use!

For details on the technical data, use, maintenance and storage of the pH sensors, see the separate documentation provided by the sensor manufacturer. Read and follow the instructions.

Calibration

As a general rule: Calibration of a pH sensor always must be carried out **BEFORE** autoclaving. This is executed on the touch screen operating panel. For details refer to the separate operating manual of the touch screen software.

INFORMATION

If the pH sensor has already been calibrated externally, the bio-reactor will use this data and there is no need for calibration on the operating panel. This only applies to digital pH sensors.

Mounting

To prevent the pH sensor from being damaged due to collision with solid materials, the sensor is mounted into a 19 mm port in the vessel top plate by the means of a probe protection. For details see main chapter “Accessories”, chapter “Probe Protection for pH sensor”.

3.9 pO₂ Control

The oxygen saturation of the (culture) medium is measured by the pO₂ sensor, and can be adjusted as follows:

Increasing the pO₂

The content of the oxygen dissolved in the medium (pO₂) can be increased using the following methods:

- Increasing the stirrer speed
- Increasing the gas volume flow rate (air and/or oxygen)
- Increasing the oxygen content in the Gasmix

These approaches can also be combined

pO₂ reduction

In anaerobic processes, the vessel can be gassed using nitrogen. This displaces the oxygen dissolved in the medium.

For details about pO₂ control refer to the separate operating manual of the touch screen software.

Measurement system

Depending on the variant selected, the measurement system for pO₂ is equipped and configured for analogue or digital sensors manufactured by METTLER or digital sensors manufactured by HAMILTON.

Measurement system variants	Properties
METTLER analog	<ul style="list-style-type: none"> ■ Conventional, amperometric/polarographic pO₂ sensor ■ Type: InPro 6820
METTLER digital	<ul style="list-style-type: none"> ■ pO₂ sensor with integrated opto-electronics ■ Type: InPro 3253i, ISM with choice of: <ul style="list-style-type: none"> - Classic, with Opto-Cap, straight - HD, with Opto-Cap angled, with “Anti-Bubble” technology low-noise measurement signal
HAMILTON digital	<ul style="list-style-type: none"> ■ pO₂ sensor with integrated opto-electronics ■ Type: Visiform RS485-ECS with choice of: <ul style="list-style-type: none"> - ODO Cap H3, standard applications - ODO Cap H4, convex, more robust

Setup and Function

Polarisation

Polarographic pO₂ sensors must be polarised for initial operation or after they have been disconnected from the power source.



INFORMATION

Digital pO₂ sensors are preconfigured by the device manufacturer INFORS HT. Replacement sensors must be configured before use.

For details on the technical data, maintenance and storage of the pO₂ sensors, see the separate documentation provided by the sensor manufacturer. Read and follow the instructions.

Measurement and Calibration

Generally speaking, the following applies: Unlike measurements such as pH, which are calibrated to absolute measurement values, the oxygen measurement is always calibrated to a relative reference point. For this purpose, the calibration is set to 100 % relative oxygen saturation, usually with air at max. stirring speed and maximum gas flow rate. The absolute concentration of dissolved oxygen in mmol/L may therefore vary at 100 % saturation, depending on the process.



INFORMATION

Depending on the specifications defined by the user, the pO₂ sensor will be calibrated either before the vessel is filled with medium or afterwards, in the prepared medium.

For details about calibration refer to the separate operating manual of the touch screen software.

Mounting

pO₂ sensors are mounted into a 12 mm / Pg13.5 port by the means of a sensor holder. For details see main chapter “Accessories”, chapter “Sensor Holder”.

3.10 Antifoam Control

Foam hinders the exchange of gas between the medium and the gas phase in the head space. The exit gas filter can become clogged with foam, which causes a pressure build-up in the vessel. This can be prevented by adding antifoam agent.

The antifoam agent is kept in a reagent bottle that is connected to the antifoam sensor and the antifoam pump via a hose. The sensor also acts as a dosing needle. When the sensor comes in contact with foam, the antifoam pump is activated and antifoam agent is fed into the vessel via the dosing needle.



INFORMATION

The antifoam sensor is separately available, it is NOT included in the standard packages. For details refer to main chapter “Accessories”, chapter “Antifoam Sensor”.

Options

4 Options

The following options are available in addition to the equipment included in the scope of supply for the basic unit.

4.1 Pump(s)

In addition to the four pumps available as standard, two additional analogue peristaltic pumps (*Feed 2* and *Feed 3*) can be integrated. As for the standard analogue feed pump, its speed can be variably adjusted in steps of 0.1 % within a range from 0 % to 100 %.



External Pump(s)

One or more Watson Marlow 120U/DV external peristaltic pump(s) are also available. The number of possible external pumps depends on the options already available.

Like the other analogue peristaltic pumps, the pump speed is adjustable and can be set in steps of 0.1 % within a range of 0 % to 100 %.

For further information on safety, use, maintenance and technical data of the pump(s), refer to the separate documentation of the pump manufacturer.

4.2 Balances

The touch screen software allows the connection of one balance to the bioreactor. If more than one balance is to be connected, the connection via the bioprocess software *eve*[®] is required.

Balances of the following type are available from the device manufacturer:

- Kern DS 30K0.1-A
- Kern FKB 6K0.02-B
- Mettler MA6002
- Mettler MA32001L

In addition to a specific device firmware, these balances also require a suitable configuration, which is carried out by the device manufacturer. This is the only way to ensure smooth functionality.

Non-configured and non-listed models are not supported.

If, however, a non-listed balance is to be integrated or several balances of a compatible type are to be used, there is the option of

integration into the eve bioprocess software®. Please contact the device manufacturer.

4.3 Exit Gas Analysis

In order to allow the user to draw conclusions regarding the status of the culture while the bioprocess is still underway, the CO₂ and O₂ measurements are often taken and analysed in the exit gas flow of the bioreactor.

4.3.1 Measurement Systems (Gas Sensors)

As measurement system for exit gas analysis are combined CO₂ and O₂ gas sensors of the type BlueInOne Ferm, BlueInOne Cell or BlueVary available.

Measurement ranges gas sensors

Type gas sensor	Vol. % CO ₂	Vol. % O ₂
BlueInOneFerm	0 to 10	1 to 50
	0 to 25	1 to 50
BlueInOneCell	0 to 10	0 to 100
BlueVary (cartridge ZrO ₂)	0 to 10	0.1 to 50
	0 to 25	0.1 to 50
BlueVary (cartridge eC)	0 to 10	0 to 100
	0 to 25	0 to 100
	0 to 25	0 to 25

For details on the safety, technical data, usage, and maintenance requirements for the gas sensors, see the separate documentation provided by the sensor manufacturer BlueSens. Read this documentation before using the gas sensor and follow the instructions contained therein.

4.3.2 Connecting the Gas Sensors

In order to view measurements on the operating panel, the measuring system for exit gas analysis must be connected to the bioreactor.

The gas sensor must be connected to the sensor cable and the bioreactor's exit gas must be led into the sensor via hose line. Generally, the cable connection is established only once during installation and remains then. The connection to the exit gas line must be re-established before each cultivation process

Options

The ideal connection conditions are detailed in the separate documentation provided by the manufacturer.

Connecting the sensor cable

The fixed sensor cable is pre-installed in the factory (rear of device). The cable has an 8-pin round plug connector. In order to connect the sensor, the plug connector is plugged into the socket marked Port **A** on the gas sensor.

Due to the length of the sensor cable, the gas sensor can be positioned in a large number of possible locations.

Establishing the hose connection

3 m of pressure hose, D = 8 x 14.5, and a hose clamp are provided with the device in order to establish the hose connection between gas sensor and culture vessel (exit gas filter).

The hose connection between the culture vessel (exit gas filter) and the gas sensor must be designed in line with the direction in which the gas flows through the gas sensor.

Proceed as follows:

Procedure

1. Cut as short a piece as possible off the supplied pressure hose.
2. Push one end of the hose onto the hose nozzle (observe direction of flow) on the gas sensor's flow adapter and fasten in place with the clamp.
3. Push the open end of the hose onto the exit gas filter on the exit gas cooler.



INFORMATION

Do NOT use a clamp here, as the hose must be easy to disconnect at this point, e.g. for autoclaving the culture vessel.

4.3.3 Calibration

1-point calibration must be carried out once per month and after installation in order to guarantee exact measurement results.

This is done directly on the gas sensor itself. The procedure is described in the separate documentation provided by BlueSens.

4.3.4 Replacing the BlueVary Gas Sensor Cartridge

The max. operating time of a BlueVary gas sensor cartridge amounts to 9000 operating hours. Once this limit is reached, measurement is no longer possible. I.e. there is no measurement value output anymore and the display turns red. The gas sensor cartridge must be replaced by the sensor manufacturer.

4.4 Multiplexer (Gas Switching Module)

To be able to measure exit gas values - usually O₂ and CO₂ - while bio processes are running in parallel, every single bioreactor usually has to be equipped with the corresponding measurement system (see chapter "Exit Gas Analysis"). Using one or more of the device's manufacturer's Multiplexers makes it possible to use only a single measurement system for this. The exit gases from the individual bioreactors are directed sequentially to the measurement system used by means of the gas switching module(s). The determined values are assigned to the corresponding bioreactor.

When using Multiplexers, the measurement information for the individual culture vessels is not available continually since one measurement sensor sequentially measures the exit gas of all culture vessels. The measurement interval achievable for each culture vessel depends, among other things, on the gas volume stream and the hose type used as well as its length.

4.5 Permissive Measurement

Sensors of the ABER Futura systems measure the permittivity (also: *capacitance*) and conductivity of the culture. This measured data can be used to determine a correlation with the live biomass concentration, for example, using the soft sensor in eve® or data evaluation.

The sensor with the corresponding transmitters must be purchased directly from the manufacturer ABER. INFORS HT offers a connection to the transmitter on the basic unit.

Measured parameters	Value	Unit
Permittivity	0 to 400	pF cm ⁻¹ range
Conductivity	0 to 40	mS cm ⁻¹ range

Calibration is performed according to the manufacturer's guidelines directly on the transmitter.

Options

All information about the ABER Futura system is available in the separate documentation provided by the manufacturer.

4.6 Conductivity Measurement

A sensor with a construction based on the 4-electrode principle is used to measure the conductivity in the medium. This ensures excellent linearity in the measurement range from 1 to 30 000 $\mu\text{S}/\text{cm}$. The transmitter is integrated in the sensor head.

Technical specifications	
Sensor, type	Conducell 4USF ARC with built-in electronics
Measurement range	1 $\mu\text{S}/\text{cm}$ to 300'000 $\mu\text{S}/\text{cm}$
Accuracy	$\pm 3\%$ at 1 to 100'000 $\mu\text{S}/\text{cm}$ $\pm 5\%$ at 100 to 300'000 $\mu\text{S}/\text{cm}$



INFORMATION

Conductivity sensors are preconfigured by the device manufacturer INFORS HT. Replacement sensors must be configured before use!

Calibration

The conductivity sensors are pre-calibrated ex-factory. They have a self-diagnosis function which, among other things, also outputs calibration recommendations. In order to be able to use this function, the corresponding software or hardware must be obtained directly from the sensor manufacturer.

For details about technical data, use and maintenance of the conductivity sensor, refer to the separate documentation from the sensor manufacturer.

Mounting of the sensor

Conductivity sensors are mounted into a 12 mm / Pg13.5 port in the vessel top plate by the means of a sensor holder. An additional adapter is necessary for mounting the sensor into a 19 mm port. For details about the sensor holder see the main chapter "Accessories", chapter "Sensor Holder".

4.7 Pressure Control

The standard device is built for pressure-free operation. It is mandatory to have a pressure control installed, if a cultivation process under pressure is foreseen.

WARNING

Overpressure in the glass vessel may cause the vessel to burst or break. Any build-up of pressure must be avoided without the pressure control option!

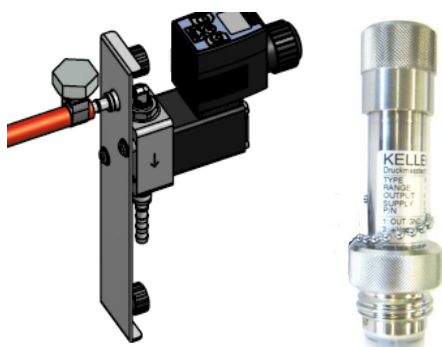

Pressure control consists of a solenoid valve (proportional valve) and a piezo-resistive pressure sensor with O-ring (the O-ring is not visible in the picture to the left).

Depending on the device configuration, the solenoid valve is situated next to or below the gassing unit on the right side of the device.

CAUTION

Risk of slight burns when touching the hot solenoid valve!

The solenoid valve heats up when under electric voltage, which is the case as soon as the device is switched on.

The pressure hose for connection to the exit gas filter during operation i.e. cultivation is installed when the device is stalled.

Pressure control is set and activated in the touch screen software in parameter *Pressure*. Control is possible up to 400 mbar.

If pressure control is switched off (parameter *Pressure OFF*), the valve automatically opens to prevent build-up of pressure in the vessel.

For details about the touch screen software refer to the separate operating manual.

Options



The pressure sensor is mounted into a 19 mm port in the vessel top plate. A threaded adapter is used for this (refer to chapter “Accessories” for details).

A plastic cap protects the steel membrane from damage. A screwed on steel cap protects the female cable plug during autoclaving.

- 1 Threaded steel cap
- 2 Hollow screw
- 3 Protective cap (plastic)

Before autoclaving

The pressure sensor is mounted into a 19 mm port in the vessel top plate and autoclaved with the culture vessel.

Proceed as follows for the mounting:

Procedure

1. Fit a threaded adapter into the 19 mm port in the vessel top plate.
2. Carefully remove the protective cap from the steel membrane of the sensor.



! ATTENTION

The steel membrane is very sensitive and can be damaged by friction or knocks from hard objects.

Carefully mount the pressure sensor by hand. Do not use any tool!

3. Ensure the sensor is equipped with an intact O-ring, fit one if necessary.
4. Carefully screw the pressure sensor into the threaded adapter.
5. Screw the steel cap onto the female sensor connector.

After autoclaving

The exit gas filter (on the exit gas cooler) must be connected to the pre-installed pressure hose of the solenoid valve. This ensures that the exit gas is led via solenoid valve into the atmosphere i.e. into the exit gas line, which has to be installed on-site by the provider.

The sensor cable must be connected to the pressure sensor, too.

Proceed as follows:

Procedure

1. Fit the pressure hose from the solenoid valve to the exit gas filter.
2. Unscrew the steel cap from the cable plug on the sensor.
3. Plug the male plug of the sensor cable into the female plug on the sensor.

To do so, the red mark on each plug must be aligned.

**Maintenance**

Basically, the pressure sensor is maintenance-free. The recalibration interval depends on the operating conditions. However, annual recalibration is recommended by the sensor manufacturer.

Accessories

5 Accessories

The following table lists all accessories included in the standard package of the device.

Accessories	Quantity
Base tray	1
Single helix impeller	1
Double helix impeller	1
Anchor impeller	1
Pitched blade impeller (45°)	1
Fork blade impeller	1
Immersion pocket for temperature sensor in Ø 10 mm port	1
Blanking plug for Ø 10 mm port	1
Blanking plug for Ø 12 mm/Pg13.5 port	4
Blanking plug for Ø 19 mm (with O-ring) port	3
Blanking plug for Ø 40 mm port	1
Addition port adapter, quadruple, for Ø 19 mm port	1
Threaded adapter for Ø 19 mm port	3
Inoculation needle and septum collar for Ø 19 mm port	1
Septum collar for Ø 12 mm port	1
Probe protection for Ø 19 mm port (pH sensor)	1
Starter set	1
Reagent bottle and pump holder for 250 mL reagent bottles	1



INFORMATION

The following chapters describe the standard accessories supplied with the device and optional accessories, too.

5.1 Base Tray



Culture vessels are delivered with a base tray made of stainless steel.

Dimensions: 373 mm × 373 mm

5.2 Reagent Bottle and Pump Holder



The culture vessel is autoclaved along with reagent bottles, hoses and pump heads.

For easy handling, a holder for three 250 mL reagent bottles and pump heads is available.

Accessories

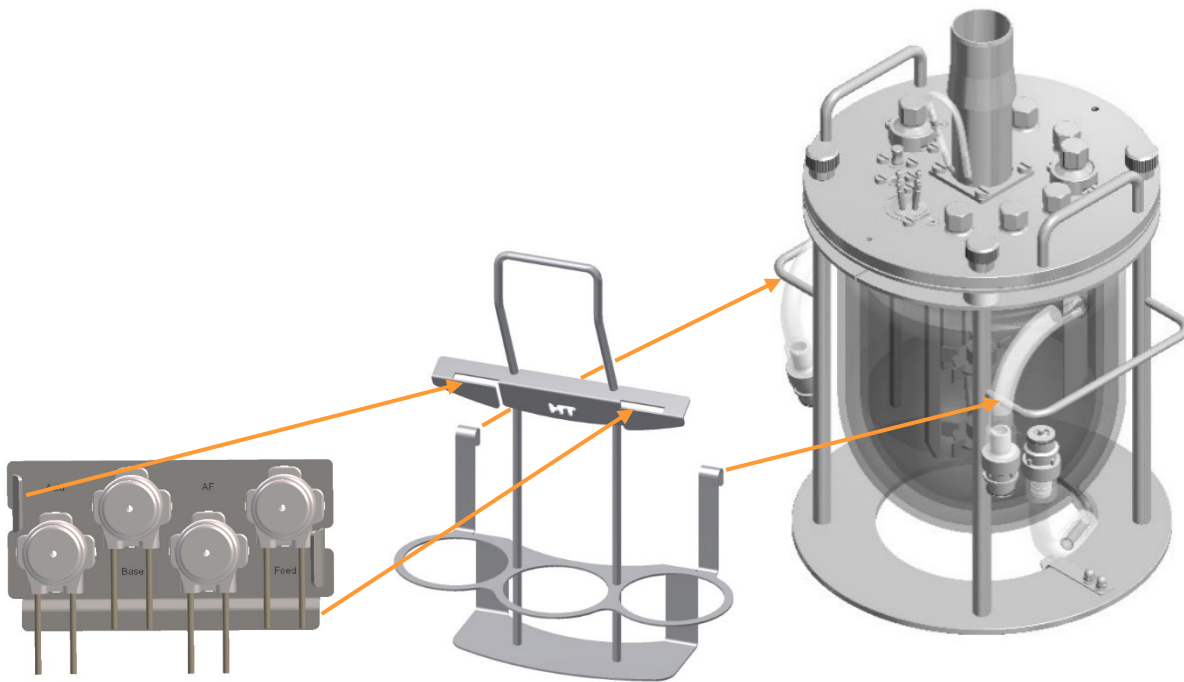

The reagent bottle and pump holder can be fitted to the vessel holder. The mounting plate with the pump heads can be fitted to the reagent bottle and pump holder.

5.3 Sampling System Super Safe Sampler

Basically, different systems and also individual components are available for sampling. This operating manual describes the operation and handling of the aseptic sampling system Super Safe Sampler combined with a dip tube.

The use of the Super Safe Sampler prevents the culture vessel from contamination when sampling.



INFORMATION

The Super Safe Sampler is designed only for removing liquid substances. If the medium contains solids, this can clog the hoses or valves. Hence, you should only remove samples of completely liquified medium.

Content of the set

The set consists of a completely pre-assembled group of valves with hoses and two syringes. It is connected via silicone hose with a dip tube.



Valve assembly

- 1 Sterile filter
- 2 Check valve
- 3 Luer activated sample valve
- 4 T-piece
- 5 Hose

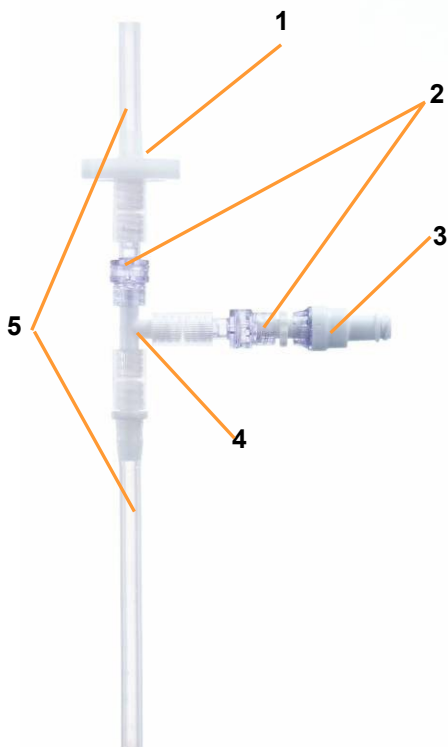

The valve assembly consists of a T-piece, two check valves, a Luer-activated automatic sample valve, a sterile filter, a length of hose as an adapter for the syringe and another hose for connection to the sample dip tube in the culture vessel.

Accessories

Principle of function

The sample valve on the side arm of the T-piece opens by putting the Luer connector of the syringe into the valve and closes by removing the syringe. No further handling is necessary.

Unintentional re-introduction of the sample material once it has been withdrawn is prevented by a check valve. Thus, contamination of the bulk culture is impossible.

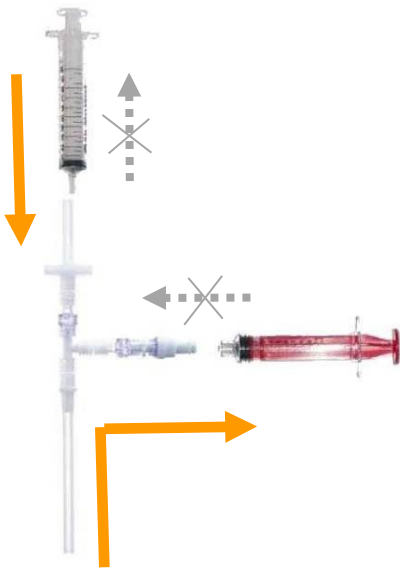

Following sampling, a second syringe can be fitted and air pushed in via the sterile filter, in order to displace culture solution from the sample hose and the dip tube of the vessel. With a conventional sampling system, the next sample cannot be taken immediately, as rinsing of the sampling hose and the immersion tube is necessary. By previously removing most of the culture in the sampling line, this sampling system can save culture volume, which is particularly important with small vessels and/or frequent sampling.

The dead volume of the culture remaining in the group of valves after flushing with sterile air amounts to a few μL and is negligibly small. If the withdrawal of a very small sample volume is required, with minimum possibility of falsification, a small quantity of culture solution (e.g. 1 mL) can be introduced and rejected before the actual sample is taken.

Designated use

The Super Safe Sampler is designed for aseptic sampling of completely liquid samples.

Solid parts in the sample may lead to clogging of the valves.

Therefore, employing the Super Safe Sampler for solid media is not recommended.

The Super Safe Sampler is autoclavable (not the syringes!) and for this reason reusable.

Practical tips for the use of the Super Safe Sampler

Sterility of the culture vessel is ensured at all times without the possible measures mentioned below.

The use of a sterile syringe and sterile caps is only necessary if the sample has to be processed under sterile conditions. For sampling, the same non-sterile syringe can be used repeatedly, without fear of contamination of the culture vessel.

Aseptic Sampling

For each sample, use a new, sterile syringe with Luer Lock fitting, in order to ensure the sterility of the sample.

Sterile syringes are consumables and therefore not included in the set.



INFORMATION

The use of another syringe is also possible. But a syringe with Luer lock prevents unwanted movement of the syringe.

- Before fitting the syringe, disinfect the sample valve. For this, spray a commercially available disinfectant onto the valve.
- After spraying and after each sampling, close the the sample valve with a sterile Luer-Lock cap (Dead End Cap) to keep the valve and sample sterile.

The caps are not included in the kit. Very convenient to use are so-called combi-caps that fit on male and female connectors alike.

Caps that are vented and made of steam sterilisable material can also be fitted during autoclaving.

Accessories

5.4 Sparger with Sterile Sheath

Gas entry takes place either via head space (standard) or sparger gassing (option). Using sparger gassing, the gas mixture is fed directly into the medium via a sparger (air pipe). The sparger is mounted in a 19 mm port in the vessel top plate using a clamping adapter and affixed using two slotted-head screws. The sparger is mounted and connected to the gassing system on the basic unit via a silicone tube with a sterile filter.

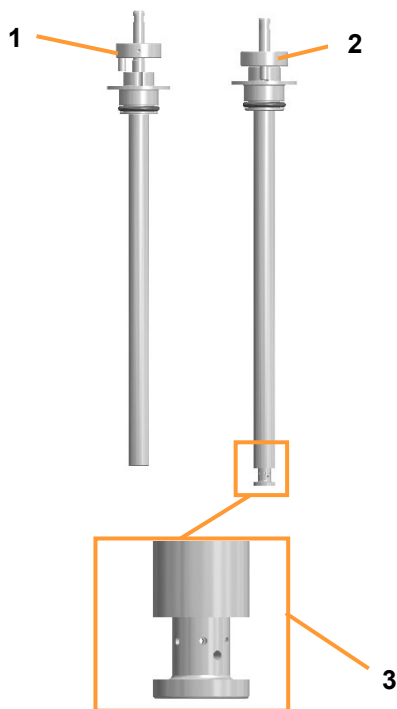

To prevent the sparger from clogging up due to solids in the medium, the sparger is protected by a sterile sheath. Once the medium is liquified, the sparger can be extended and gassing can be started.

- 1 Sterile sheath with retracted sparger
- 2 Sterile sheath with extended sparger
- 3 Sparger in extended state

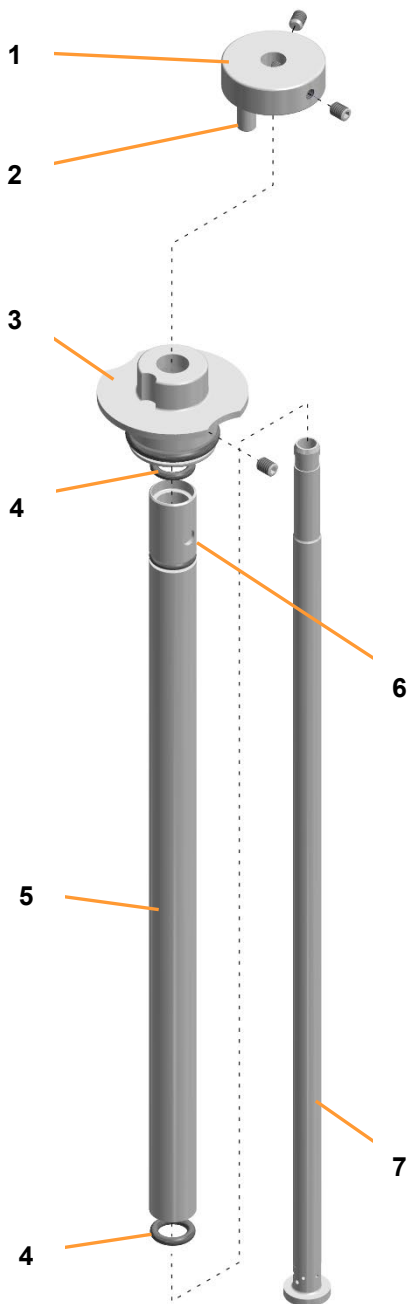

The sparger with sterile sheath consists of the following individual parts:

- 1 Hand ring with grub screws
- 2 Screw-mounted pin
- 3 Sterile sheath cover with O-ring and grub screw
- 4 O-ring
- 5 Sterile sheath
- 6 Indentation for the grub screw of the sterile sheath cover
- 7 Sparger



INFORMATION

When gassing directly into the medium using the sparger, gassing may only be started once the sparger is extended.

Accessories

5.5 Impellers

For details about impellers, refer to chapter “Setup and Function”, “Stirrer”.

5.6 Immersion Pocket for Temperature Sensor (Pt100)

The immersion pocket is a pipe with a sealed bottom end, and is used to insert the temperature sensor.

Immersion pocket Ø 10 mm

Fitted with O-ring.

Two slotted screws are used for fixing in the 10 mm.

The picture on the left does not show the full length of the immersion pocket.



5.7 Blanking Plugs

Blanking plugs are used to seal open ports. There are different blanking plugs for the different types of port.

Blanking plug, Ø 10 mm

Fitted with O-ring.

Two slotted screws are used for fixing in 10 mm port

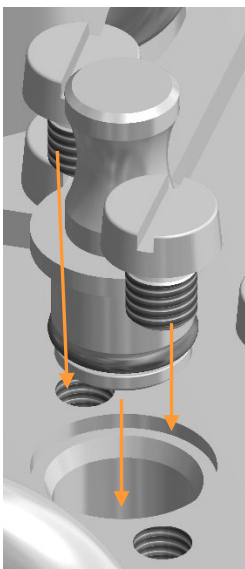

Blanking plug, Ø 12 mm

Must be fitted with an O-ring before being mounted in the 12 mm/Pg13.5 port.

Mounted using a thread.



Blanking plug Ø 19 mm

Fitted with O-ring.

A threaded adapter is used for mounting in 19 mm port.

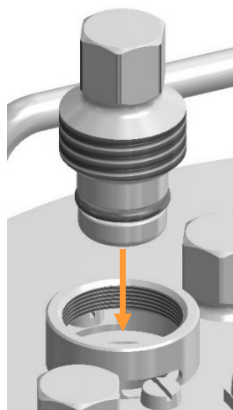

Blanking plug Ø 40 mm

Fitted with O-ring.

Two slotted screws are used for fixing in 40 mm port.

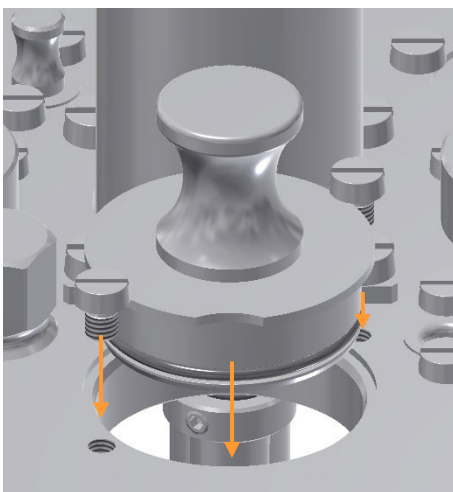

Accessories

5.8 Addition Port Adapters

Addition port adapters are used for liquid addition into the culture vessel. They are mounted in a port in the vessel top plate and end in the headspace of the vessel. They have one or several hose connections and various models are available.

The following can be connected to addition port adapters:

- Reagent bottles with feed solution, antifoam agent or corrective reagent (base/acid).
- If appropriate, exit gas line
- If appropriate, gassing hose for headspace gassing

Addition port adapter, quadruple, Ø 19 mm

Inside-Ø	3.0mm
Outside-Ø hose connection	4.0 mm

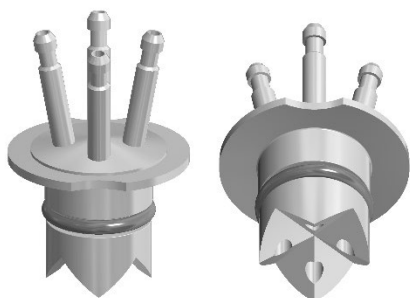

Fitted with O-ring.

Two slotted screws are used for mounting in 19 mm port.

Addition port adapter Ø 12 mm

Inside-Ø	3.0 mm
Outside-Ø hose connection	5.0 mm

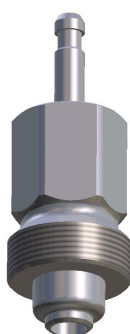

Muts be fitted with O-ring.

Thread is used for mounting in 12 mm / Pg13.5 port.

5.9 Inoculation Needles

Inoculation needles are used for feeding liquids into the culture vessel, which cannot be autoclaved with the culture vessel. These liquids may be e.g. the inoculum or heat-sensitive reagents.

If using an inoculation needle, then a septum (inoculation membrane) must be fitted along with a septum collar in the appropriate

port. The inoculation needle is connected with the reagent bottle and autoclaved. The liquid, e.g. the inoculum, which shall to be added into the culture vessel, is shortly before addition filled into the reagent bottle under sterile condition. The septum is then pierced with the inoculation needle, which is screwed into the septum collar. The septum may be wetted e.g. with an alcohol solution that is lit up before the piercing.

Inoculation needles are purchased including septum collar. They have an oblique tip to facilitate the piercing. The hose connection and the very sharp needle tip are covered with non-autoclavable(!) protective caps.



INFORMATION

For addition of autoclavable liquids, addition port adapters or inoculation needles without septum and without septum collar are suitable, too. These must be mounted in the ports and connected to the reagent bottles before autoclaving.

Inoculation needle Ø 12 mm

Inside-Ø	2.5 mm
Outside-Ø hose connection	4.5 mm

Fitted with O-ring.

Thread is used for mounting in septum collar for a 12 mm / Pg13.5 port.



Accessories



Inoculation needle, Ø 19 mm

Inside-Ø	2.5 mm
Outside-Ø hose connection	4.5 mm

Fitted with O-ring.

Thread is used for mounting in septum collar in 19 mm port.



Inoculation needle, 19 mm

Inside-Ø	4.0 mm
Outside-Ø hose connection	6.0 mm

Fitted with O-ring.

Thread is used for mounting into septum collar in 19 mm port.



Inoculation needle, double, Ø 19 mm

Inside-Ø	2.0 mm
Outside-Ø hose connection	4.0 mm

Fitted with O-ring.

Thread is used for mounting in septum collar in 19 mm port.

5.10 Septum Collars

Septum collars are either used in combination with the corresponding inoculation needle with septum or with a syringe with injection needle and a septum. Inoculation needles are always supplied including a septum collar, but septum collars are separately available, too.

Septum collar, Ø 12 mm

With internal thread.

A septum must be inserted in the 12 mm / Pg13.5 port before mounting.

A thread is used for mounting.



Accessories

Septum collar, Ø 19 mm



With inside thread.

Septum must be inserted in port before mounting in 19 mm port.
Threaded adapter is used for mounting.

Multi-inlet septum collar, system Roussel, Ø 19 mm

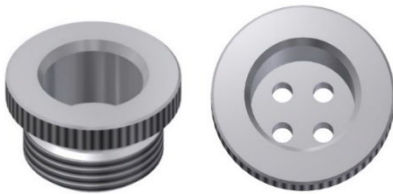

Without inside thread, for inoculation with syringe.

Septum must be fitted in 19 mm port before mounting.
Threaded adapter is used for mounting.

5.11 Probe Protection for pH Sensor

The probe protection protects the pH sensor from collisions with solid parts in the medium. The pH sensor is installed by screwing it into the probe protection. Only the end of the sensor will remain free within the medium.



Inside-Ø	12 mm
Outside-Ø	19 mm

Fitted with O-ring.

Two slotted screws are used for fixing in the 19 mm port.

5.12 Dip Tubes

Dip tubes are open at both ends and are mounted in a vessel top plate port with a clamping adapter.

Dip tubes are used for a variety of purposes:

- For filling the culture vessel after autoclaving. Using a dip tube prevents foaming.
- For adding inoculum.
- For sampling. The aseptic Super Safe Sampler system can be used for sampling.
- For harvesting
- For siphoning off medium during continuous cultivation
- For draining the culture vessel

Depending on the purpose, silicone hoses are connected to the dip tube via other vessels, sampling systems or, if necessary, hose trees.

Multiple dip tubes can be used at any one time, providing that enough vessel top plate ports are available.

Different types of dip tubes are available.

Dip tube, straight, Ø 6 mm

Inside-Ø	3.0 mm
Hose connection outside-Ø	4.2 mm / 5.0 mm



The dip tube does not reach as far as the bottom of the vessel. The illustration on the left shows only the upper section of the dip tubes.

Accessories

Dip tube, straight Ø 12 mm

Inside-Ø	10 mm
Hose connection outside-Ø	12 mm

The dip tube does not reach as far as the bottom of the vessel.
The illustration on the left shows only the upper section of the dip tube.



Dip tube, curved with horizontal tip, Ø 6 mm

Inside-Ø	4,0 mm
Hose connection outside-Ø	6.0 mm

The dip tube does reach to the vessel bottom.



5.13 Clamping Adapters

Clamping adapters are used for mounting the sparger, the various dip tubes and the antifoam/level sensors. The clamping adapter fixes the component part in place and can be used to adjust its mounting depth.

The clamping adapter must match the outside diameter of the part to be mounted and the size of the port.

Clamping adapter Ø 6 mm / 10 mm

Fitted with O-ring (B).

Two slotted screws are used for mounting in 10 mm port.

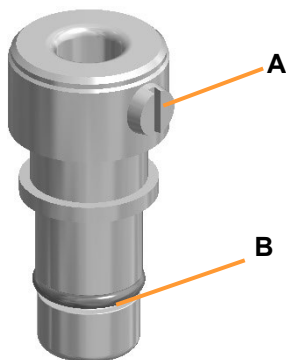

After loosening the slotted screw (A) the component part with Ø 6 mm can be inserted into/pulled out from the clamping adapter. The component part is fixed in the clamping adapter by fastening the slotted screw.

Clamping adapter Ø 6 mm / 12 mm

Must be fitted with O-ring before mounting.

Thread is used for mounting in 12 mm / Pg13.5 Port.

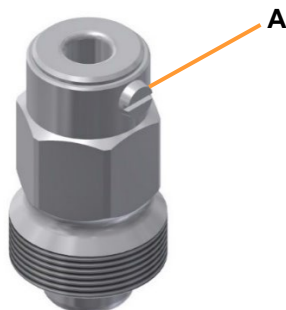

After loosening the slotted screw (A) the built-in part with Ø 6 mm can be inserted into/pulled out from the clamping adapter. The built-in part is fixed in the clamping adapter by fastening the slotted screw.

Clamping adapter, Ø 6 mm / 19 mm

Fitted with O-ring (B).

Threaded adapter is used for mounting in 19 mm port (see chapter "Threaded Adapter")

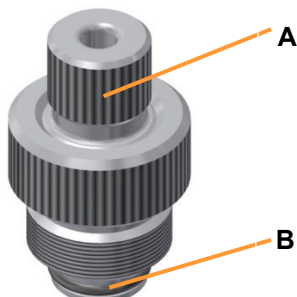

After loosening the hollow screw (A) the component part with Ø 6 mm can be inserted into/pulled out from the clamping adapter. The component part is fixed in the clamping adapter by fastening the hollow screw.

Accessories

Clamping adapter, Ø 12 mm / 19 mm

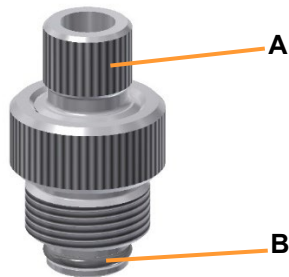

Fitted with O-ring (B)

A threaded adapter is used for mounting in 19 mm port.

After loosening the hollow screw (A) the built-in part with Ø 12 mm can be inserted into/pulled out from the clamping adapter. The built-in part is fixed in the clamping adapter by fastening the hollow screw.

5.14 Sensor Holder

Sensor holders are used to adjust the mounting depth of sensors (pH, pO₂, etc.) in 12 mm/Pg 13.5 ports. The sensor holder, respectively the sensor must be fitted with an O-ring for mounting.

The sensor holder comprises a sheath with a grub screw, a guide bar with a fork, and a hollow screw. The wrench for the grub screw is also included in the scope of supply.

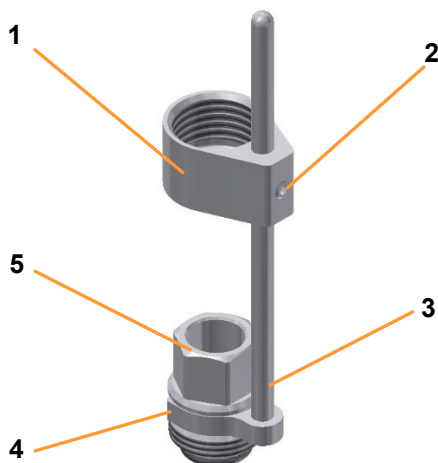

- 1 Sheath
- 2 Grub screw
- 3 Guide bar
- 4 Fork
- 5 Hollow screw

5.15 Threaded Adapter



The threaded adapter has an inside thread and is used for mounting blanking plugs or clamping adapters with \varnothing 19 mm in (threadless) 19 mm ports in the vessel top plate. Two slotted screws are used for mounting.

5.16 Adapter



The adapter is used for component parts with \varnothing 12 mm into a (thread less) 19 mm port in the vessel top plate. Fitted with O-ring.

Accessories

5.17 Exit Gas Cooler

The exit gas cooler dries the exit gas through condensation, thus preventing the exit gas filter from becoming clogged with moisture. At the same time, it also prevents liquid loss in the culture medium. The exit gas is passed through the cooling pipe of the exit gas cooler. The cooling is done by water, which is led through the jacket of the cooling pipe. A baffle in the cooling pipe serves to extend the residence time of the exit gas in the cooling pipe. The water supply to the exit gas cooler is provided by the basic unit. The water flow rate can be adjusted using the manual valve on the basic unit.

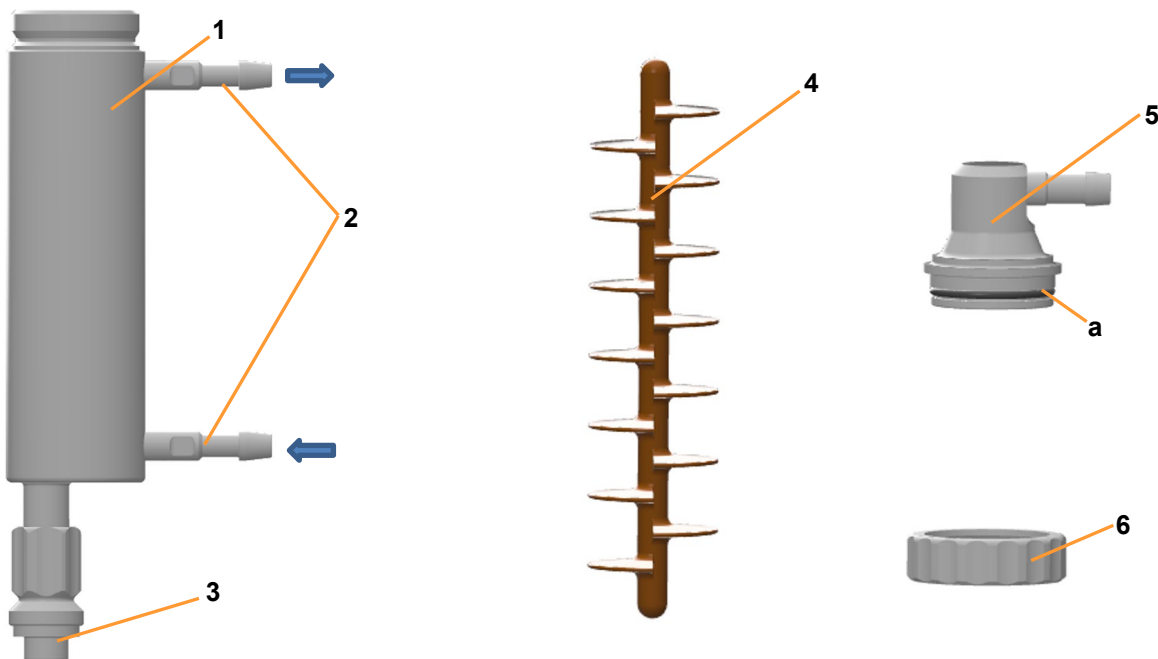

- | | | | |
|---|---|---|---------------------|
| 1 | Cooling pipe with jacket | 4 | Baffle (silicone) |
| 2 | Hose connections water inlet (lower) and water outlet (upper) | 5 | Lid with O-ring (a) |
| 3 | Screw thread | 6 | Coupling nut |

The exit gas cooler is supplied pre-fitted with a piece of pressure hose an exit gas filter and pressure hoses for water inlet (lower connector) and water outlet (upper connector). Hoses and filter are secured with hose clamps. Appropriate hoses with rapid couplings and plug-in nozzles for connection to the basic unit are included.

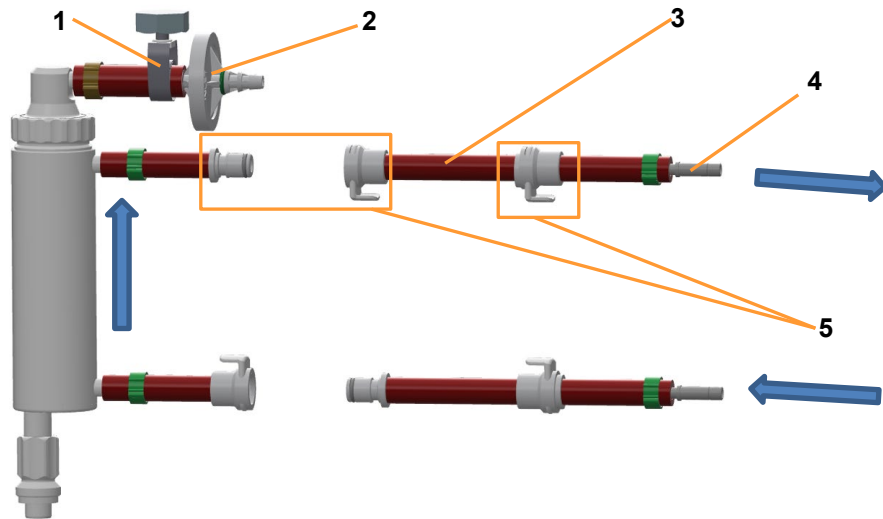

- | | | | |
|---|-----------------------|---|----------------|
| 1 | Adjustable hose clamp | 4 | Rapid coupling |
| 2 | Exit gas filter | 5 | Plug-in nozzle |
| 3 | Pressure hose | | |

Important notes

- The exit gas cooler only works when the temperature control system is switched on.
- The exit gas filter must be replaced with a new filter after each cultivation process.

Mounting

- Exit gas cooler Ø 12 mm: must be equipped with O-ring. Its thread is used for mounting in 12 mm / Pg13.5 Port.
- Exit gas cooler Ø 19 mm: fixed with O-ring. A threaded adapter is needed for mounting into 19 mm port.

Accessories

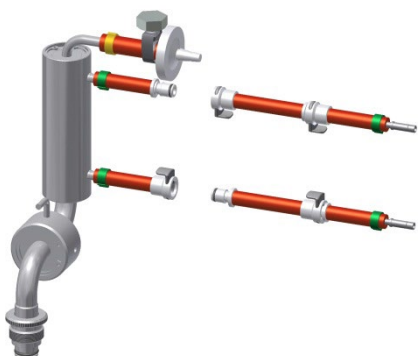

- Exit gas cooler, model swivelling sideways, Ø 19 mm: fixed with O-ring. A threaded adapter is needed for mounting into 19 mm port.

i INFORMATION

This model is made entirely of stainless steel and cannot be dismantled into individual parts.

5.18 Reagent Bottles

For addition of corrective reagent and feed solution (substrate) into the culture vessel, different sizes and models of reagent bottles made of borosilicate glass are available.

Size	Ø Hose	Number of hose connectors
250 mL ¹⁾	2 x 6 mm	2
250 mL	2 x 6 mm	3 + 1
500 mL ¹⁾	2 x 6 mm	2
500 mL	2 x 6 mm	3 + 1
1000 mL	3 x 5 mm	2
2000 mL	3 x 5 mm	2
5000 mL	3 x 5 mm	2
10'000 mL	3 x 5 mm	2

¹⁾ These two bottle sizes fit into the reagent bottle and pump holder.

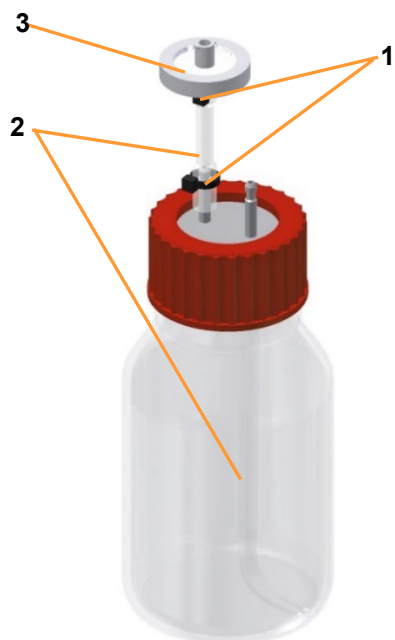

The reagent bottles are already equipped on delivery.

- 1 Cable tie
- 2 Silicone hose
- 3 Filter

Reagent bottles with two hose connectors are provided as standard.

Two hose connectors are situated on the lid. One is equipped with a short piece of silicone hose with filter for pressure equalisation. The second connector is equipped with a piece of silicone hose on the inside of the lid.

A piece of silicone hose is included to establish the hose line from the reagent bottle to the addition port adapter in the vessel top plate and to the pump head.

The individual parts of the reagent bottle are:



- 1 Threaded cap, PBT
- 2 Plate with two hose nozzles, PVDF
- 3 Flat gasket, silicone
- 4 Laboratory bottle, Borosilicate

Accessories



The picture to the left shows the reagent bottle type with 3 + 1 hose connectors.

5.19 Antifoam Sensor

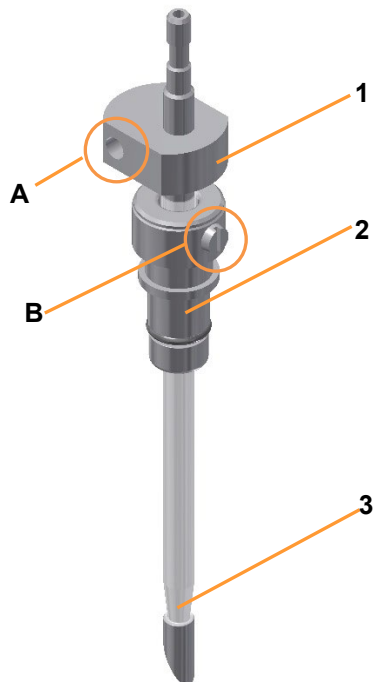

If ordered, the antifoam model fitting into Ø 10 mm ports is supplied by default. A clamping adaptor with O-ring is used for mounting.

- 1 Sensor head with port for banana connector (A)
- 2 Clamping adaptor with slotted screw (B)
- 3 Needle with transparent insulation

The antifoam sensor is equipped with two NON-autoclavable protective caps.

Models for Ø 12 mm / Pg13.5 or 19 mm ports with appropriate clamping adaptors are available, too.

Port	Inside-Ø	Outside-Ø hose connection
Ø 10 mm	2 mm	4 mm
Ø 12 mm / Pg13.5	3 mm	4 mm
Ø 19 mm	3 mm	4 mm

5.20 Pump Heads

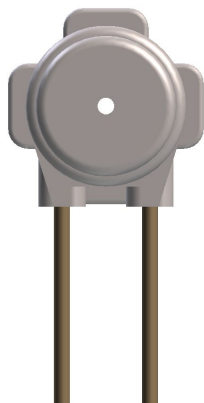

The autoclavable pump heads are fitted with PharMed pump hoses prior to delivery. Three different hose diameters are available for different delivery rates:

- 1.0 mm (standard)
- 0.5 mm
- 2.5 mm

For more detailed information about pumps and hoses refer to main chapter “Technical Data”, chapter “Specifications”, “Pumps”.

5.21 Sterile Filters

Sterile filters are used to protect against contamination in both the gassing line and the exit gas line. In addition to this, all reagent bottles used for pressure equalisation must be fitted with a short piece of hose with a filter.

All the sterile filters in the scope of supply are autoclavable, disposable filters with PTFE diaphragms.



INFORMATION

Sterile filters must be clean and dry at all times, and should thus ideally be replaced after each use.

Ø 37 mm, marked red



Application	Supply air
Retention rate	0.2 µm

Accessories

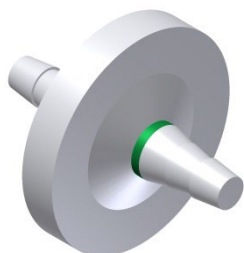

Ø 37 mm, marked green

Application	Exit gas
Retention rate	0.3 µm dry 1.0 µm wet

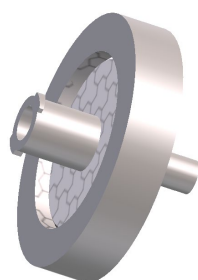

Ø 25 mm, not marked

Application	Super Safe Sampler
Retention rate	0.2 µm

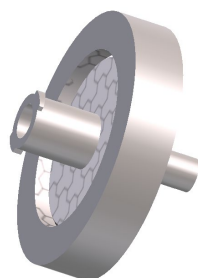

Ø 25 mm, not marked

Application	Reagent bottles (pressure equalisation)
Retention rate	0.45 µm
Diaphragm	PTFE

Ø 50 mm, Type ACro50 TF, no label

Usage	Inlet air ¹⁾ / Exit gas ²⁾
Retention rate	0.2 µm

1) For high gas flows rates

2) For absolute sterility

5.22 O-Rings and Gaskets

Description	Ø mm	Utilisation
O-ring, EPDM	1.5 x 7.5	Gasket, port size 10 mm
O-ring, EPDM	2.62 x 10.77	Gasket, port size 12 mm / Pg13.5
O-ring, EPDM	2.5 x 15.0	Gasket, port size 19 mm
O-ring, EPDM	2 x 36	Gasket, port size 40 mm
O-ring, EPDM	3.53 x 158.34	Top plate gasket, culture vessel DN 150
O-ring, EPDM	1.78 x 6,07	Sparger
O-ring, EPDM	1.5 x 7	Sparger
O-ring, EPDM	1.78 x 5,28	Clamping adapter Ø 6 mm
O-ring, EPDM	1.5 x 11.5	Probe protection for pH sensor
Flat gasket, Silicone	32 x 42 x 2	Gasket for reagent bottle lid (for all sizes with two hose connections)
O-ring, EPDM	2.0 x 26	Lid gasket exit gas cooler

5.23 Hoses and Accessories

Hose type	Ø mm	Utilisation
Pressure hose, fibreglass-woven	10 x 17	Water outlet
Pressure hose, fibreglass-woven	8 x 14,5	Water inlet and exit gas filter attachment (on exit gas cooler)
Pressure hose, fibreglass-woven	6 x 11,9	Gas connection(s) and water supply and return, for exit gas cooler
Silicone hose	5 x 8	Gassing (sparger)
Silicone hose, transparent	2 x 6	Reagent bottles: 250 mL und 500 mL (hose lines for reagents)
Silicone hose, transparent	3 x 5	Reagent bottles: 1000 mL, 2000 mL, 5000 mL, 10'000 mL (hose lines for reagents)
Silicone hose, 60° Shore,	10 x 16	Water connections vessel jacket (double walled culture vessels)

Accessories

Hose Fitting	Ø mm	Utilisation
Hose clamp, screw with screwdriver slot, INOX	14	To fasten hose/hoses for gas connection
Hose clamp, screw with screwdriver slot, INOX	17	To fasten hose for water inlet
Hose clamp, screw with screwdriver slot, INOX	19	To fasten hose for water outlet
Hoffmann pinchcock, nickel-plated brass	12	To clamp off hose lines, e.g. on unused addition port adapters, the sparger hose etc.
Cable tie, polyamide	2,4 x 85	Hoses for reagent bottles and pumps, inlet air filter, sparger, dip tube of sampling system.
Hose connector, 3/32" x 1/16", PVDF	---	Pump heads with hoses to reagent bottles with internal-Ø 1 mm
Hose connector, 1/8" x 1/8", PVDF	---	Pump heads with hoses to reagent bottles with internal-Ø 2.5 mm
Rapid coupling plug nozzle, DN12.7 hose nozzle 1/2" A	---	water inlet and outlet hoses of vessel jacket (double walled culture vessels)
Rapid coupling plug nozzle DN12.7 hose nozzle 1/2"	---	water overflow hose of vessel jacket (double walled culture vessels)

5.24 Inoculation Accessories and Tools

Description	Application
Hexagon socket spanner, WAF 17	Blanking plugs 12 mm/Pg13.5 ports
Hex key, WAF 2, DIN911,	Grub screws impellers
Septum, Ø = 16 mm MVQ Silicone, transparent	12 mm/Pg13.5 ports

6 Transport and Storage

The following specifications are based on transport and storage of an unpacked device at the provider's site.

6.1 Transport



WARNING

Improper transport, the use of incorrect auxiliary equipment and careless handling of the device may lead to injuries and severe property damage.

The following points must be observed when transporting the device internally (relocation):

- Always work in pairs and use suitable auxiliary equipment when transporting the device.
- The entire device (basic unit and culture vessel) contains delicate glass parts.
- Especially when using auxiliary tools, it is important to observe that the device's centre of gravity is not in the middle.



WARNING

The entire device (basic unit and culture vessel) is too heavy to be carried by one person alone.

Even the basic unit on its own exceeds the weight that should be carried by one person alone.

Transport and Storage

6.2 Storage

- Before each time they are put into storage, decontaminate, thoroughly clean and dry the culture vessel and all accessories ¹⁾.
- Store the device and its components clean, dry and protected against dust, dirt and liquids.
- Store the device and its components in a cool place with low air humidity but protected against frost.
 - Storage temperature: 5 °C to 55 °C
 - Relative air humidity, non-condensing: 10 % to 95 %.
- Protect the device from aggressive media, direct sunlight and mechanical vibrations.

¹⁾ *Maintain and store sensors produced by other manufacturers in accordance with the separate documentation.*

7 Installation and Commissioning

Installation and commissioning of the device may only be carried out by qualified personnel from the manufacturer or personnel authorised by the manufacturer.



WARNING

Installation and commissioning require qualified and experienced personnel. Faulty installation may lead to dangerous situations or severe loss of property.

Only let carry out installation and commissioning by the manufacturer's qualified personnel or authorised personnel by the manufacturer only.

Therefore, the following sections only list the energies that must be provided and the connection requirements that are to be respected on site by the provider.

Exception

The basic functions of the bioreactor are tested and demonstrated at the same time to the operator in form of a short test run on site during installation by the qualified personnel.

In order to become familiar with the basic functions of the bioreactor before the first cultivation or after a longer period of non-use of the device, the operator may afterwards carry out this short test run any time, too.

For details refer to chapter "Test Run".

7.1 General Location Requirements for Installation

The following requirements must be met for the installation of the device:

- The figures and ranges specified in the main chapter "Technical Data", chapters "Connection Values" and "Operating Conditions" must be observed.
- The device must only be installed inside a laboratory or a laboratory-like environment.
- The installation site must be level, sufficiently stable and able to bear loads.
- There must not be any sources of electrical interference near the device.

Installation and Commissioning

7.2 Minimum Distances

To operate and maintain the device it must be installed with a minimum spacing of 150 mm from walls, ceilings or other equipment.

7.3 Power Supply

The in-house electric power supply of the device must meet the following conditions:

- Single-phase, constant power supply
- Type 230 V / 50/60 Hz
- Type 115 V / 60 Hz

The power supply of the device must be made safe by the use of an FI-switch (or RCD – Residual Current Device) of the kind RCCB, Type B on the customer's side.

7.4 Water Supply and Return

The in-house water supply to the device, as well as the drainage of the water, must meet the following requirements

- “Very soft” or “soft” water quality (CaCO_3 concentration 0 mmol L^{-1} to 1.5 mmol L^{-1})



ATTENTION

Not observing the water quality requirements may lead to damage or failure of the device.

The heating system has protection against dry running which is based on measurement of conductivity. Therefore, the heating does not work or does not work properly when using demineralised or distilled water as cooling liquid!

- Constant water supply at a pressure of 2 ± 1 bar
- Inlet temperature 10 °C up to 20 °C
- Manometer to check the primary pressure available
- The drain is heat-resistant and without back pressure

Installation and Commissioning

Hoses

- Only use pressure-resistant and intact hoses.
- Only use appropriate hoses, use adapters as necessary.
- Secure hoses with the appropriate clamps.

7.5 Gas Supply

The in-house gas supply to the device must meet the following requirements:

- Constant gas supply at a pressure of 2 ± 0.5 bar
- Gas(es) is/are dry, clean and free of oil and dust
- Recommended compressed-air quality as per DIN ISO 8573-1: Class 1,2,3,4



ATTENTION

The use of impure gases can lead to blockage of the sterile filter and damage the mass flow controller.

Only use dry, clean and oil-free gases.

Hoses

- Only use pressure-resistant and intact hoses.
- Only use appropriate hoses, use adapters as necessary.
- Secure hoses with the appropriate clamps.



WARNING

The use of inappropriate or damaged hoses and/or inappropriate fixing may lead to leakage of gases. Depending on the gas in question, there may be a danger of gas explosion and/or danger of suffocation as well as a hazard for the health of the operator.

Always close the gas supply before a hose is removed and when the device is not in use.

Installation and Commissioning

7.6 Exit Gas

Ensure the following on the house side:

- The exit gas is safely discharged by means of a suitable, gas-tight hose.
- The working environment is equipped with an adequate ventilation system, depending on the application.

7.7 Test Run

In order to become familiar with the basic functions of the bioreactor before the first cultivation or after a longer period of non-use of the equipment, a short test run can be executed.

The test run comprises:

- Temperature control (cooling / heating)
- Stirring
- Gassing

Normal compressed air is used for gassing. To avoid calcium deposits, demineralised water is recommended for filling the vessel.

The following description of the test run does not detail handling of individual components, e.g. stirrer, sparger etc. Detailed descriptions of their handling are given in the corresponding chapters of the main chapter “Before Cultivation”.



ATTENTION

Risk of damaging the glass vessel due to inappropriate handling of removing & mounting the vessel top plate! Strictly follow the instructions stated in the appropriately named chapters.

For details on operation, refer to the separate operating manual of the touch screen software.

7.7.1 Preparation Test Run

Before starting the test run, check and ensure the following:

- All required services are available and activated
- All services have the correct connection pressure

Installation and Commissioning

The following work is to be executed before the test run:

Procedure

1. Remove the vessel top plate (without tools!) and put it aside carefully.



ATTENTION

If the vessel top plate presses against long built-in components they may be distorted due to the weight of the top plate.

Always position the vessel top plate so that it does not lie on top of components.

2. Fill the culture vessel with water – preferably demineralised – to the working level.
3. Ensure that the stirrer and the sparger (if used) are mounted. If necessary, mount them.
4. Fit the top plate and Fix the knurled nuts cross-wise by hand! For this, strictly follow instructions stated in chapter “Fitting the Vessel Top Plate”.
5. Check the lubrication of the mechanical seal. For details about lubrication of the mechanical seal, refer to chapter “Cleaning and Maintenance”, “Lubricating the Mechanical Seal”.



INFORMATION

Lubrication of a new device is not necessary. When carrying out a test run on a device which has not been in use for a longer period of time, controlling the lubrication of the mechanical seal, and if applicable, its lubrication, is imperative.

If an exit gas cooler is used:

6. Screw the exit gas cooler into the port on the vessel top plate port.

The exit gas cooler is equipped with a new exit gas filter in the factory.
7. Connect the exit gas cooler to the basic unit; follow the symbols on the basic unit:

water inlet on bottom of exit gas cooler / water outlet at top of exit gas cooler.
8. Close all remaining open ports with blanking plugs.

If no exit gas cooler is present or it is not used:

 - Close the manual valve for water flow of the exit gas cooler on the basic unit.
 - One port in the vessel top plate must be open!

Installation and Commissioning

9. Connect the culture vessel to the basic unit. Therefore connect the water inlet, water outlet and overflow of the vessel jacket to the basic unit; follow the symbols on the basic unit.

INFORMATION

In order that the hose connections can be disconnected easily again, slightly moisten the rapid couplings on the silicon hoses prior to connecting them.

10. Equip the sparger (if used) with a piece of silicone hose (D= 5 x 8 mm) for gassing and a dry, clean inlet air filter (accessories, filter with red label).
11. Fit another piece of silicone hose for gassing (compressed air) to the hose nozzle on the basic unit.
12. Connect both hoses via the inlet air filter (connect the hose end to the hose nozzle of the inlet air filter).
13. Insert the temperature sensor as far as it will go into the immersion pocket in the top plate.

CAUTION

Risk of burns and loss of property due to elevated temperature!
The temperature control circuit will overheat without an inserted temperature sensor and/or without liquid in the vessel. This can lead to burns and loss of property.

14. Couple the motor.

INFORMATION

The motor is controlled via the basic unit. Its cable is plugged in during installation and will not be unplugged anymore during routing operation of the device.

15. Switch on the device on the power switch and wait until the system is booted.

Installation and Commissioning

7.7.2 Filling the Water Circuit

To fill the water circuit, proceed as follows:

Procedure

1. Set a low setpoint for parameter *Temperature* (e.g. 10 °C), in order to activate the water supply into the vessel jacket.
2. Start the bioreactor.
All parameters except for *Temperature* remain switched off; switch them off if necessary.
You should hear and see water flowing into the vessel jacket.

If using an exit gas cooler:

The water supply of the exit gas cooler is activated now.



INFORMATION

The exit gas cooler only works with activated temperature control (Parameter *Temperature* ON).

3. Use your hands to check whether the exit gas cooler is beginning to cool down. Open the valve for water flow on the basic unit, if necessary.
When the circuit is full, water escapes from the overflow on the vessel jacket and flows into the water outlet.
4. Wait for min. 1 minute.
This ensures that no air is left in the temperature control circuit.

7.7.3 Stirring

Bioreactor is running with temperature control switched on

To test the stirrer, proceed as follows:

Procedure

1. On the operating panel for the parameter *Stirrer*, set a low setpoint.
For further information about the different ranges of rotation speed refer to the specification in main chapter "Technical Data".
2. Switch the parameter on.

For the rest of the procedure, allow the bioreactor to run with the temperature control switched on and the stirrer running.

Installation and Commissioning

7.7.4 Heating and Adjusting Temperature

Bioreactor is running with temperature control switched on and running stirrer

To test the heating and adjust the temperature, proceed as follows:

Procedure

1. On the operating panel, set a high setpoint for parameter *Temperature*, e.g. 45 °C.
The water supply for cooling is stopped; the system heats up.
The temperature of the liquid (water) in the vessel jacket starts increasing.
2. Wait until the temperature has adjusted to the setpoint.

For the rest of the procedure, allow the bioreactor to run with the temperature control switched on and the stirrer running.

7.7.5 Gassing

Bioreactor is running with temperature control switched on and stirrer running

To test the gassing, proceed as follows:

Procedure

1. If applicable, slowly open the rotameter needle valve.
2. If applicable, set a low setpoint in the appropriate parameter *Flow* (depending on the configuration) and switch the parameter on.
3. If applicable, ensure that all other gas parameters (e.g. *Gas-mix*, *GM Flow* etc.) are switched off.
If the gassing is working, air bubbles now form in the water in the culture vessel.

7.7.6 End of Test

After all parameter setpoints have been reached, the test can end here.

Proceed as follows:

Procedure

1. Stop the bioreactor on the operating panel and shut down the system.
2. Switch off the device on the power switch.

Installation and Commissioning



ATTENTION

Switching the device off at the power switch without previously stopping the bioreactor and shutting down the system on the operating panel may lead to damage of the operating panel!

3. Shut off the supply lines.
4. Let the motor cool down.



CAUTION

Risk of minor burns if the motor is touched during operation or its cooling phase!

When the motor has cooled down:

5. Uncouple the motor from the vessel and place it on a clean and dry work surface.
6. Empty the culture vessel.

Before Cultivation

8 Before Cultivation

The following chapters describe all the preparatory work before starting the cultivation process. This essentially comprises:

- Preparing and autoclaving the culture vessel:
 - Checking the gaskets (O-rings) on component parts and culture vessel
 - Mounting component parts
 - Filling or moistening the culture vessel
 - Preparing sensors and other accessories
 - Autoclaving
- Connecting the culture vessel and preparing for cultivation:
 - Connecting the cables and hoses between the culture vessel and the basic unit
 - Filling the vessel if necessary
 - Preparing sensors and other accessories

8.1 Preparing and Autoclaving the Culture Vessel

All accessories required for later cultivation must be prepared and mounted accordingly and autoclaved together with the culture vessel.

8.1.1 Mounting the Glass Vessel in the Holder

The following procedure describes how to insert and fix the glass vessel in the vessel holder. It is necessary to strictly follow the procedure in order to avoid any damage to the glass vessel or other components.

Proceed as follows:

Procedure

1. Position the vessel holder on a stable and flat surface.



2. Place the black shock-absorbing ring under the collar of the vessel.



i INFORMATION

The vessel illustrations serve as an example and do not show the original culture vessel. The O-ring on the upper edge of the vessel jacket is not used and is not present on the original vessel.

3. Bring the two parts of the vessel flange under the vessel collar and hold them in position. The bevelled edge of the two parts of the flange must point upwards.



Before Cultivation

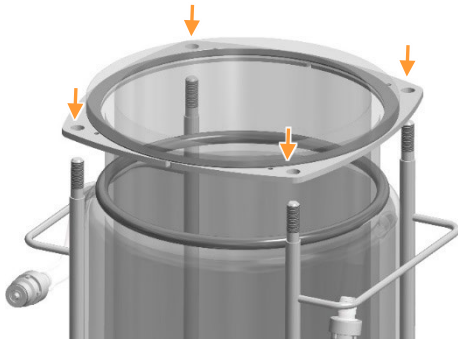

4. Lower the glass vessel onto the vessel holder and insert the holder's rods into the holes of the vessel flange at the same time. Carefully set the vessel down.

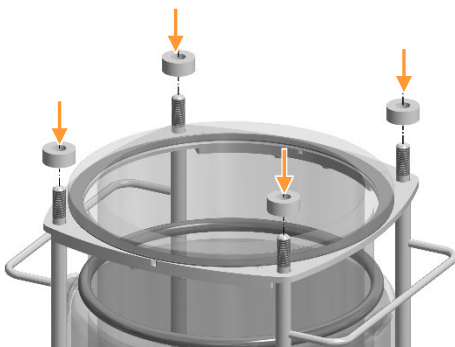

5. Place the white spacers on the rods of the vessel holder.

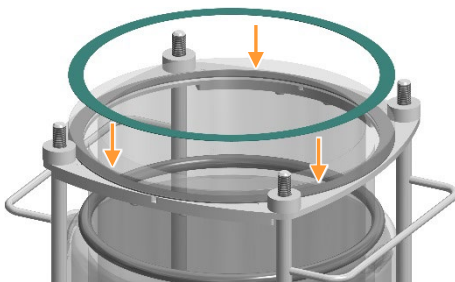

6. Place the second shock-absorbing ring (green) on top of the vessel collar.

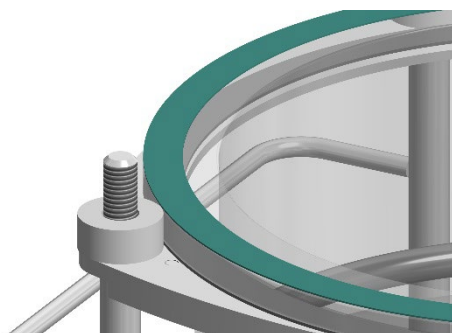

7. Make sure that the shock-absorbing ring is correctly positioned on the vessel collar and is not shifted. The shock-absorbing ring must not overlap the outer edge of the vessel.

Before Cultivation

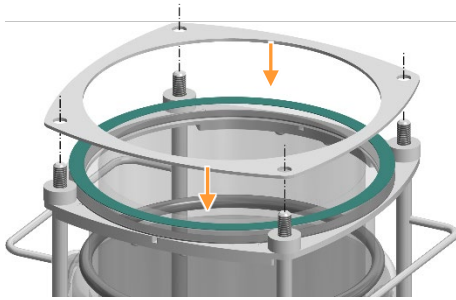

8. Position the stainless steel ring on top of the white spacers. Insert the rods of the vessel holder into the holes of the steel ring.

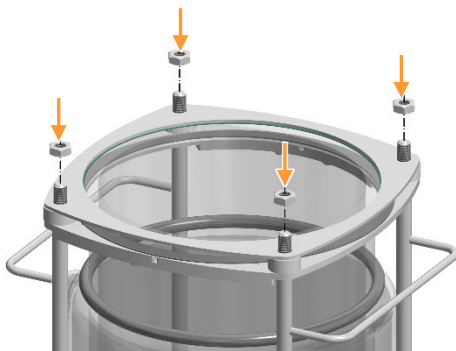

9. Fix the stainless steel ring with the four lock nuts. Screw down the lock nuts crossways **by hand** until they touch the steel ring. **Do not tighten them and do not use any tool!**

! ATTENTION

If the lock nuts on the stainless steel ring are tightened too much, the glass vessel may be damaged. **Only tighten the nuts by hand!** It is imperative that they are not tightened with a tool under any circumstances.

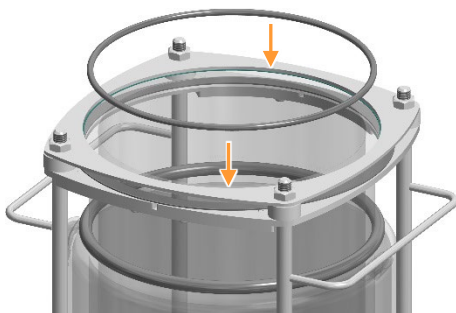

10. Place the O-ring (top plate seal) on top of the vessel. The O-ring must rest completely on the slightly protruding edge of the glass vessel within the steel ring.

Make sure that the O-ring is correctly positioned, otherwise the vessel will not be properly sealed.

8.1.2 Checking Gaskets (O-Rings)

O-rings are used to seal all openings on the vessel and top plate. The top plate, its ports and all accessories are thus equipped with O-rings. Before every use, the O-rings must be checked that they are present, undamaged and correctly seated. Damaged O-rings must be replaced.

i INFORMATION

Wet the O-rings with 70% alcohol or a little water to facilitate removing and replacing O-rings or accessories with O-rings. Do not use silicone grease; this can affect sterilisation results.

Before Cultivation

Carry out this check as follows:

Procedure

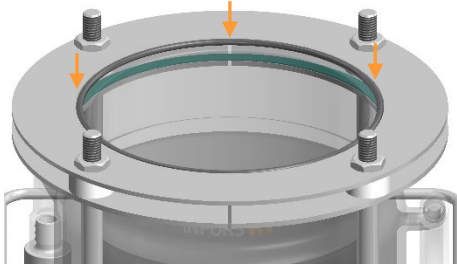

1. Check the vessel seal (O-ring) for damage and on correct seat: it must rest firmly on the slightly prominent vessel rim within the metal ring.
Place it correctly as necessary.

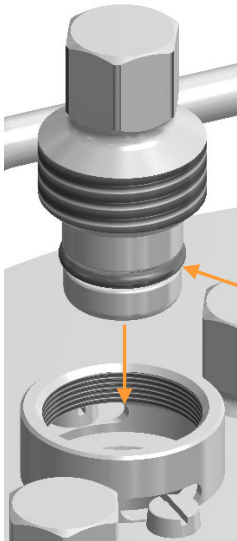

2. Ensure that each mounting part is equipped with an intact O-ring: check that O-rings are correctly positioned and undamaged. Replace or reposition, if necessary.

The figure to the left shows a blanking plug with O-ring for mounting into a 19 mm port with mounted threaded adapter.

If mounting parts have to be fitted into other mounting parts (clamping adapter), an O-ring must be placed between them, too.

i INFORMATION

Septum collars are sealed with a septum. No O-ring is used!

8.1.3 Mounting the Impellers

To mount the impellers to the stirrer shaft, proceed as follows:

Procedure

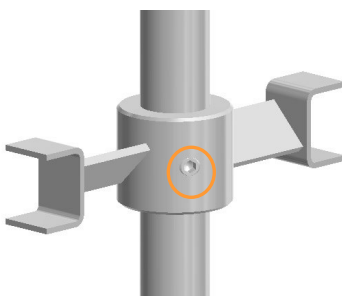

1. Slide the impeller onto the stirrer shaft.
2. Set the desired height.
3. Tighten the grub screws on the impeller with the hex key.

i INFORMATION

To avoid unnecessary foam formation, do not fit the impeller at the same height as the surface of the medium.

When mounting the impeller, observe the following:

- Only one helix impeller can be used at a time.
- If an anchor impeller is to be used, it must be fitted at the bottom.
- The impellers must not touch any other parts when rotating.

8.1.4 Assembling and Mounting the Sparger

For subsequent sparger gassing, the sparger must be prepared as follows:

Assembling the sparger

Procedure

1. Insert the sparger into the sterile sheath from below.

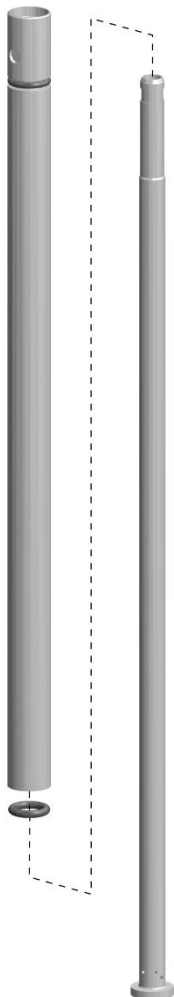

Before Cultivation



2. Insert the O-ring into the sterile sheath from above.

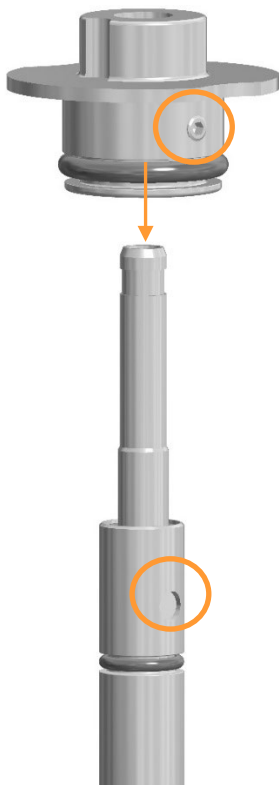

3. Place the sterile sheath cover onto the sterile sheath.
 In doing so, ensure that the grub screw in the sterile sheath cover and the indentation for affixing the grub screw on the sterile sheath are aligned on top of one another.
 The sterile sheath cover is pressed down sufficiently, if the O-ring is no longer visible on the sterile sheath.
4. Tighten the grub screw on the sterile sheath cover.

Before Cultivation

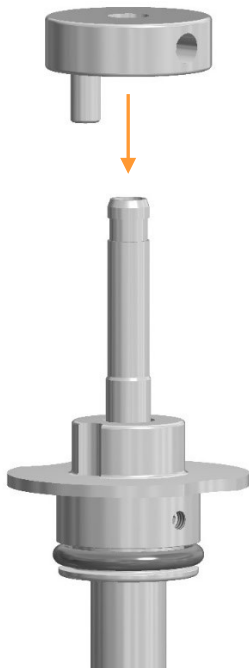

5. Move the hand ring up to the stop (and no further) on the sparger.
Ensure that the screw-mounted pin on the hand ring is placed in the direction of the sparger and does not touch the sterile sheath cover.
6. Tighten the grub screw on the hand ring.
The hand ring can now be turned freely in the sterile sheath.

Procedure

Fitting the sparger

1. Insert sparger with sterile sheath into the designated port.
2. Affix it with slotted cylinder head screws.
3. Ensure that the sparger is not extended.



ATTENTION

To avoid collisions, the installation depth of the sparger must be chosen in such a way that the sparger (also when extended) does not come into the rotation area of the stirrer.

8.1.5 Moistening/Filling the Culture Vessel

If in the culture vessel is to be autoclaved with the medium, the vessel can be filled before the top plate is put in position and the additional component parts are mounted.

Note the following about filling the culture vessel before autoclaving:

- Before autoclaving, only top up with heat-resistant media.
- During autoclaving, evaporation may result in a loss of volume and thus to increased salt concentration in the medium. If necessary, top up with sterile water.

Before Cultivation

INFORMATION

Development of steam is not possible when autoclaving an empty and dry culture vessel. Successful sterilisation is not guaranteed.

Ensure that there is liquid in the culture vessel (approx. 10 mL of water per litre of total volume).

8.1.6 Fitting the Vessel Top Plate

Proceed as follows to fit and fix the vessel top plate:

Procedure

1. Place the top plate carefully and with the correct alignment into position.

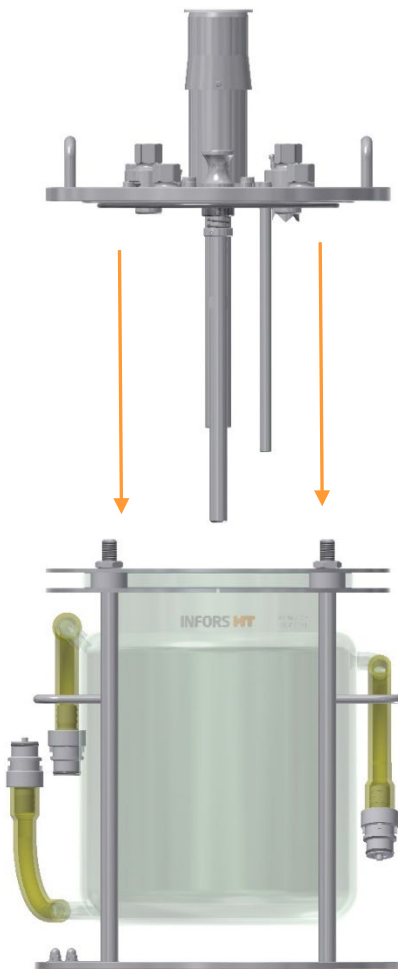

Before Cultivation

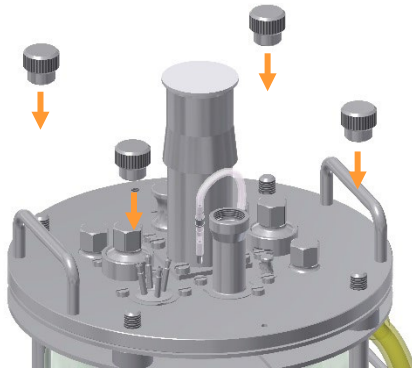

ATTENTION

If the knurled nuts on the top plate are tightened too much, the glass vessel may be damaged. **Only tighten the nuts by hand!** It is imperative that they are not tightened with a tool under any circumstances.

2. Fix the knurled nuts by hand (**no tools!**) as follows:.

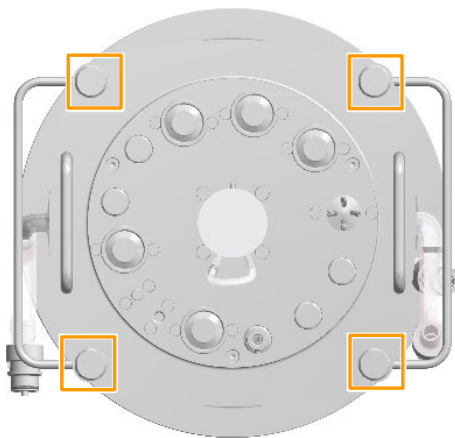

a) Slightly screw down all four knurled nuts with two fingers until the nuts are touching the top plate. Do not tighten them at this stage!

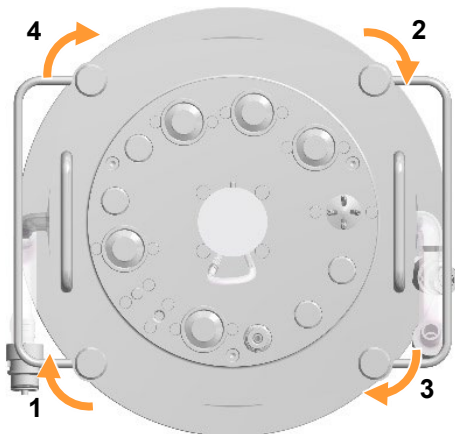

b) Tighten two nuts opposite each other (1) and (2) by 45° each (1/8 of a turn).

c) Afterwards, tighten the other two nuts (3) and (4) by 45° too (1/8 of a turn).

3. Repeat steps b) and c) two times. At the end, all knurled nuts are tightened by 135°.

Before Cultivation

8.1.7 Mounting a Threaded Adapter

To mount a threaded adapter into a 19 mm port, proceed as follows:

Procedure

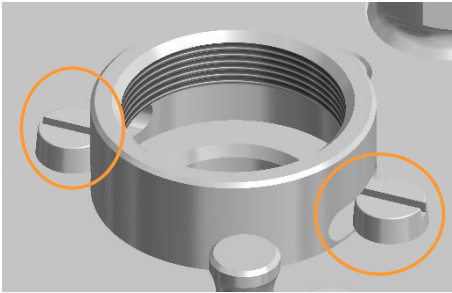

1. Position the threaded adapter correctly aligned on the 19 mm port.
2. Fix it with the two slotted screws.

8.1.8 Mounting the Blanking Plugs

For mounting the different blanking plugs, proceed as follows:

Ø 10 mm Ports

Procedure

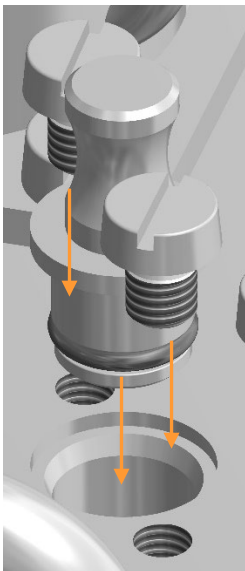

1. Insert the blanking plug with O-ring into the port.
2. Fix it with both slotted screws.

Procedure

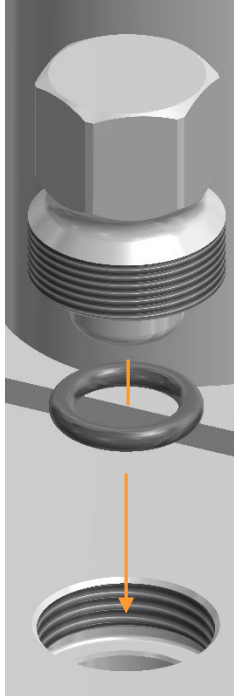

Ø 12 mm ports

1. Insert an O-ring into the port.
2. Insert the blanking plug and screw it in by hand.
3. Tighten it with the hexagon socket spanner hand tight.

Procedure

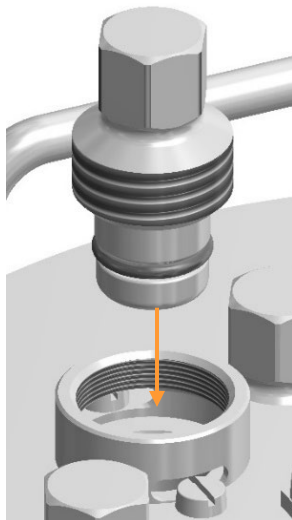

Ø 19 mm ports

1. Screw the blanking plug with O-ring into the threaded adapter.
2. Tighten it by hand.

Before Cultivation

Ø 40 mm Port

Procedure

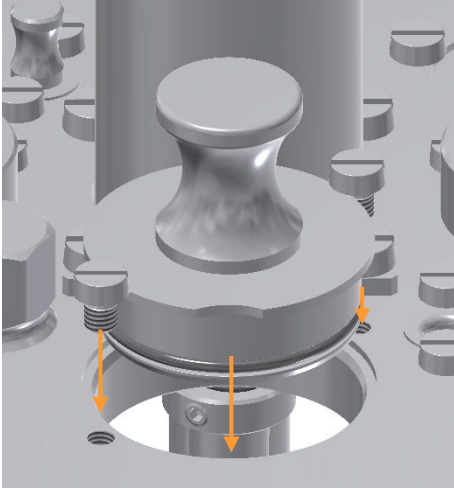

1. Insert the blanking plug with O-ring into the port.
2. Fix it with both slotted screws.

8.1.9 Mounting Addition Port Adapters

Proceed as follows for mounting:

Addition port adapter, quadruple, for Ø 19 mm port

Procedure

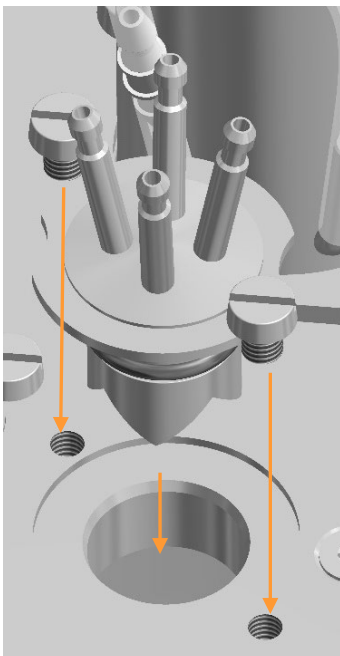

1. Insert the addition port adapter with O-ring into the port.
2. Fix it with the two slotted screws.

**INFORMATION**

The mounting procedure of further models of addition port adapters (refer to main chapter “Accessories” for details) is the same as for blanking plugs into their corresponding ports. That is why their mounting is not repeatedly described here.

8.1.10 Mounting the Immersion Pocket for Temperature Sensor (Pt100)

Proceed as follows:

Procedure

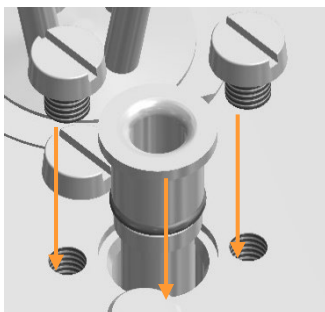

1. Insert the immersion pocket with the O-ring into the 10 mm port.
2. Fix it with both slotted screws.

8.1.11 Preparing an Inoculation Needle

To prepare an inoculation needle for later inoculation, proceed as follows:

Procedure



1. Remove protective caps from the inoculation needle.
2. Keep the septum collar ready for use.

Before Cultivation

3. Connect the inoculation needle via silicone hose with an appropriate container for the inoculum.
4. Put the inoculation needle in a sterile cover or wrap it up in some aluminium foil.

8.1.12 Equipping Port with Septum Collar and Septum for Inoculation

A port in the vessel top plate must be appropriately prepared for later inoculation. For this, it must be equipped with septum collar and septum.

Proceed as follows:

Procedure

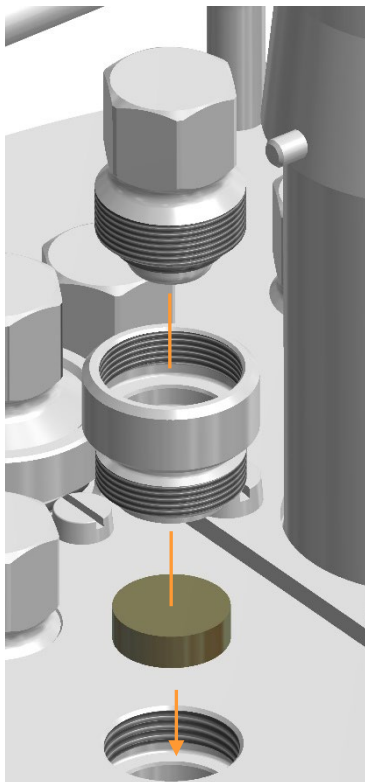

1. Ensure that the port is not equipped with an O-ring, otherwise remove it.
2. Insert the septum into the port.
3. Screw the septum collar into the port by hand.

i INFORMATION

If inoculation shall take place via 19 mm port, then mount a threaded adapter, first.

The picture to the left shows the procedure with a 12 mm / Pg13.5 port.

4. Ensure the blanking plug is equipped with an O-ring, fit one, if necessary.
5. Screw the blanking plug into the septum collar by hand.
If necessary, tighten it with the hexagon socket spanner hand-tight.

8.1.13 Mounting the Exit Gas Cooler

To mount the exit gas cooler, proceed as follows:

Procedure

1. Insert silicone baffle into the exit gas cooler.

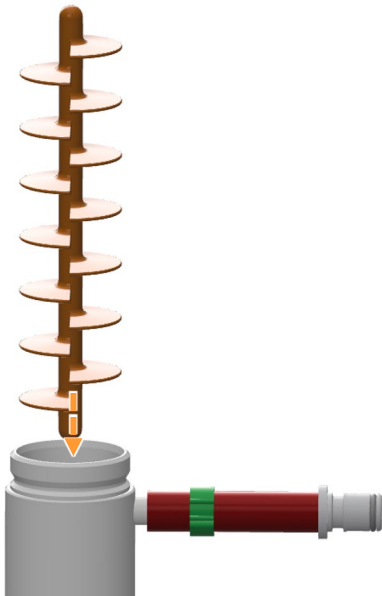

2. Place the lid with intact O-ring vertically onto the exit gas cooler by hand.
 - Align the exit gas pipe as far as possible on the same side as the hose connections.
 - The lid must sit straight and tight.

If necessary, wet the O-ring on the lid lightly with water to facilitate putting it on.

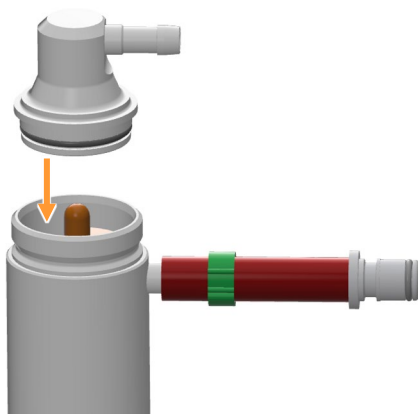

3. Attach the coupling nut and tighten it by hand in clockwise direction.

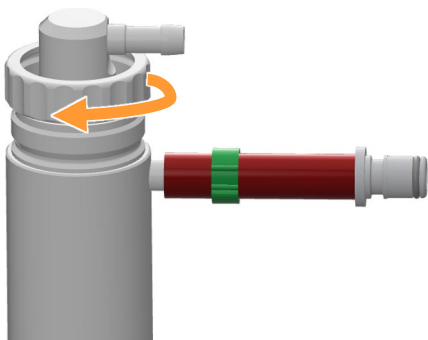

Before Cultivation

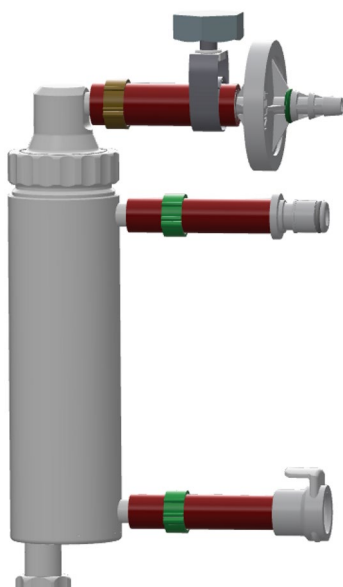

4. Equip the exit gas pipe with a piece of pressure hose (D = 8 x 14.5 mm) and a clean, dry exit gas filter. To do this, plug the inlet side (INLET) with the green marking in the piece of hose.
5. Secure the hose and exit gas filter with hose clamps (adjustable for exit gas filter).

6. Mount the exit gas cooler into the port in the vessel top plate:

a) Mounting in Ø 12 mm / Pg13.5 port

Fit an O-ring to the thread of the exit gas cooler or fit it into the 12 mm / Pg13.5 port and screw the exit gas cooler into the port by hand.

OR

b) Mounting in Ø 19 mm port

Equip the 19 mm port with a threaded adapter first and then screw the exit gas cooler (with O-ring) into the threaded adapter by hand.

7. Align the exit gas cooler to ensure that handling of other mounting parts is impaired as little as possible.
8. Check to ensure that the exit gas filter is fitted securely.
9. Cap the exit gas filter loosely with a little aluminium foil.

i INFORMATION

A humidifier bottle with antifoam reagent can be installed between exit gas cooler and the exit gas filter if significant foam formation is expected.

Before Cultivation

Take the following into account for autoclaving:

- Only use a new, clean and dry exit gas filter and fix it in such a way that it cannot slip.
- ALWAYS keep the exit gas line - hose at the exit gas cooler with secured exit gas filter - open.

⚠ CAUTION

If pressure equalisation does not take place via a top plate opening or the mounted exit gas cooler, overpressure or vacuum in the culture vessel may occur during autoclaving.

8.1.14 Checking Lubrication of the Mechanical Seal

The mechanical seal must be lubricated at any time.

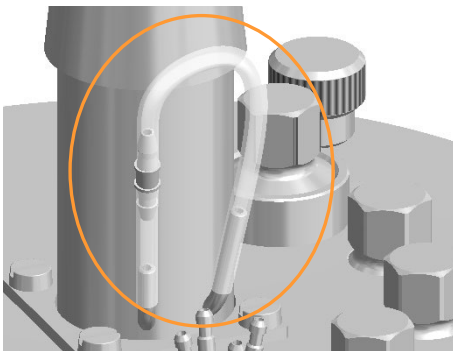

Therefore it must be ensured, that the silicone hose on the bottom of the drive hub is always entirely filled with glycerine. Top it up, if necessary.

For details refer to chapter “Cleaning and Maintenance“, “Lubricating the Mechanical Seal”.

⚠ ATTENTION

Risk of loss of property due to the mechanical seal running dry!

A mechanical seal, which has not been adequately lubricated, is destroyed when running dry.

8.1.15 Preparing the Sensors

All sensors that come into contact with the medium are mounted before autoclaving and are sterilised together with the culture vessel.

Note the following about all sensors:

- Mount all sensors by hand – do not use any tools!
- Mount the sensors in such a way that they cannot come in contact with other built-in-parts or the glass vessel.
- If the mounting depth is adjustable (mounting with sensor holder/clamping adapter), make sure the mounting depth is set correctly prior to autoclaving, as later adjustment represents a contamination risk.

Before Cultivation

- For all sensors that are mounted in a 12 mm/Pg13.5 port, only use the O-ring of the vessel top plate port. Always remove any existing sensor O-rings and support rings.

pH sensor

Calibrate the pH sensor before mounting and autoclaving.

pO₂ sensor

Mount the pO₂ sensor in such a way that it has good access to the flow and there is no risk of bubbles collecting.

Analogue pH and pO₂ sensors

Cover the sensor heads of the analogue pH sensors and pO₂ sensors with aluminium foil during autoclaving.

Digital pH and pO₂ sensors



ATTENTION

Risk of damage to the digital pH and pO₂ sensors. Covering the sensor heads with aluminium foil during autoclaving may lead to water gathering under the film, thus damage the contacts on the sensor head.

Sensor heads of the digital pH and pO₂ sensors should **NOT** be covered with aluminium foil during autoclaving.

For details on the safety, technical data, usage and maintenance requirements for the pH and pO₂ sensors, see the separate documentation provided by the manufacturers.

Notices on Assembly

- Only fit a pH sensor with probe protection.
- Only fit the pO₂ sensor with the supplied sensor holder.

8.1.15.1 Calibrating the pH Sensor

The calibration of a pH sensor must always be carried out before autoclaving. This is done on the operating panel and is described in detail in the separate operating manual of the touch screen software.

Procedure

1. Connect the sensor cable.

Before Cultivation

The different sensor and cable connections depending on the existing pH measurement system are briefly described in the chapter "Connecting the pH sensor".

2. Switch on the device at the power switch.

The operating panel is switched on automatically and the system is started.

3. Calibrate the pH sensor in accordance with the detailed description in the operating manual of the touch screen software.



INFORMATION

If the pH sensor has already been calibrated externally, the bio-reactor will use this data and the calibration procedure in the touch screen software is not necessary. This only applies to the digital pH sensors.

8.1.15.2 Fitting a pH Sensor with a Probe Protection

To avoid damage due to collision with solids, pH sensors are fitted with probe protection in a 19 mm port in the vessel top plate. To do so, proceed as follows:

Procedure

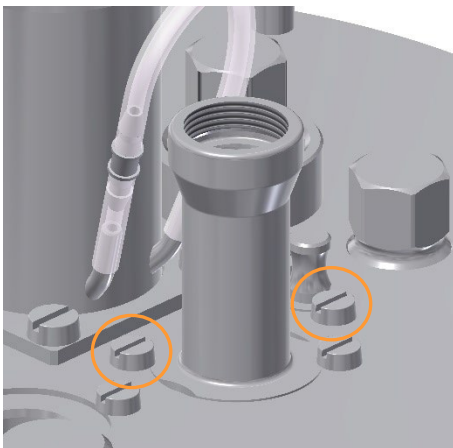

1. Insert the probe protection for the pH sensor into the corresponding 19 mm port.
2. Affix the probe protection with two slotted cylinder head screws.

3. Prior to autoclaving, manually screw the calibrated pH sensor into the probe protection.



INFORMATION

Always remove any sensor O-rings and support rings before fitting them in the probe protection!

Before Cultivation

8.1.15.3 Mounting Sensors with Sensor Holder

To enable adjusting the mounting depth of a sensor in a 12 mm/Pg13.5 port, a sensor holder must be used for mounting. Proceed as follows:

Procedure



1. On the sensor holder, lightly loosen the grub screw in the support guide with the key.

2. Pull the support guide from the guide bar.

3. Insert the sensor into the support guide and tighten it.

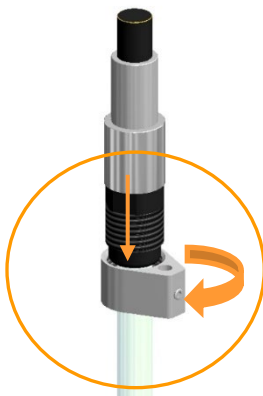

Before Cultivation



4. Insert the sensor into the hollow screw with the thread pointing in the downward direction.
5. Fit the fork of the guide bar into the groove of the hollow screw.
6. Push the hollow screw and the guide bar together upwards and insert the guide bar into the hole of the support guide.



INFORMATION

When mounting sensors in a 12 mm/Pg13.5 port, only use the O-ring of the vessel top plate port! Always remove any existing sensor O-rings and support rings.

7. Slide the O-ring onto the sensor and insert the sensor into the port.
8. Adjust the sensor to the desired mounting depth.

Before Cultivation

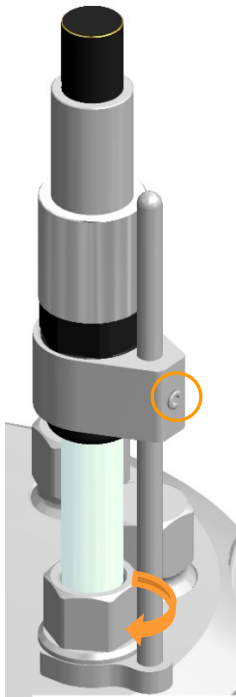

9. Screw the sensor on the hollow screw into the port and tighten it.
10. Tighten the grub screw in the support guide with the key.

8.1.16 Preparing the Super Safe Sampler

i INFORMATION

The following figures are for general purposes of comprehension.

In order to prepare the Super Safe Sampler sampling system for autoclaving, proceed as follows:

Procedure



1. Attach the hose of the valve group on the dip tube.

2. Secure the hose with a cable tie.

Before Cultivation



3. Tighten the sample valve carefully by hand in a clockwise direction.
This ensures that the non-return valve/sample valve screw connection is tight.



4. Turn the sterile filter carefully by hand in a clockwise direction.
This ensures that the non-return valve/sterile filter screw connection is tight.



5. Cover the valve group loosely with aluminium foil.

6. Clamp off the hose on the dip tube.

Before Cultivation

8.1.17 Mounting the Sparger Hose and the Inlet Air Filter

The sparger (if used) must be equipped with the hose and inlet air filter before autoclaving.

To do so, proceed as follows:

Procedure

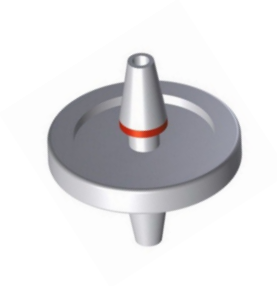

1. Cut a short piece of silicone hose.
2. Place the inlet air filter, marked in red, onto the hose end in the direction of the air flow.

The nozzle with the red INLET marking remains exposed.



3. Place the silicone hose onto the sparger.

4. Secure the ends of the hose with the cable tie.
5. Clamp off the silicon hose with a hose clamp.
6. Lightly cap the inlet air filter with aluminium foil.

8.1.18 Mounting the Hose and Inlet Air Filter for Head Space Gassing

An addition port adapter in the vessel top plate must be equipped with a hose and an inlet air filter for head space gassing before autoclaving.

To do so, proceed as follows:

Procedure

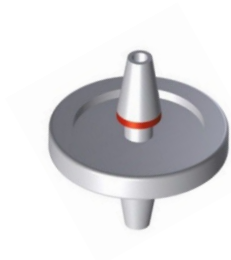

1. Cut a short piece of silicone hose.
2. Fit the inlet air filter, marked in red, to one hose end.
The nozzle with the red INLET marking remains exposed.
3. Connect the open end of the silicone hose to the addition port adapter.
4. Secure the ends of the hoses with cable ties.
If applicable, close unused inlets on the addition port adapter with hose pieces and cable ties.
5. Clamp off the silicon hose with a hose clamp.
6. Lightly cap the inlet air filter with aluminium foil.

8.1.19 Preparing the Gassing Hose Line on the Basic Unit

An appropriate hose line must be prepared on the basic unit in order to connect the addition port adapter respectively the sparger to the gassing after autoclaving.

Proceed as follows:

Procedure

1. Cut a piece of thick walled silicone hose (\varnothing 5 x 8 mm, in the starter kit).
Choose its length so that the hose connection between addition port adapter/sparger and gas supply on the basic unit does not have any tension or kinks.

Before Cultivation

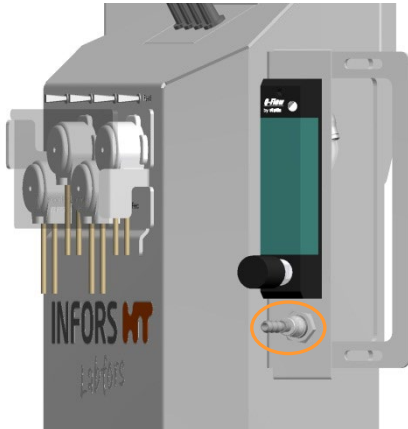

2. Fit the hose to the hose nozzle of the gassing unit(s) on the basic unit.

3. Secure the hose with cable ties.

8.1.20 Calibrating the Pumps

Not calibrated pumps show the duration in seconds and the number of rotations. If the delivered volume (in mL) shall be indicated instead, the pumps must be calibrated before autoclaving.

A detailed description of how to calibrate the pumps can be found in the separate operating manual of the touch screen software.

8.1.21 Preparing the Reagent Bottles, Pumps and Hoses

! ATTENTION

Damaged hoses and/or clogged filters may lead to undesired pressure conditions in the reagent bottles.

- Ensure each reagent bottle is equipped with an open pressure equalisation line with a clean and dry filter.
- Only use clean, intact hoses and ensure they are firmly attached.

The following sections contain a detailed description of how reagent bottles are equipped properly and connected to the pumps and culture vessel.

Before Cultivation

Connecting the reagent bottles to the pumps and culture vessel

Proceed as follows:

Procedure

1. Cut two long silicone hoses with appropriate diameter (refer to table with hoses in chapter „Accessories“, „Reagent Bottles“)per pump/reagent bottle.



INFORMATION

The length of the silicone hoses must be selected to ensure that the hose connections between the reagent bottles, pumps and culture vessel do not have any tensions or kinks.

2. Thoroughly rinse the silicone hoses with distilled water.
3. Connect the silicone hoses and pump hoses of the pump heads with hose connectors.



INFORMATION

Note that the direction of rotation of the pumps is clockwise in operational state.

4. Secure with cable ties.



Connection between pumps and culture vessel

Proceed as follows:

Procedure

1. Fit silicone hoses for base, acid and feed to the addition port adapter(s) and secure them with cable ties.

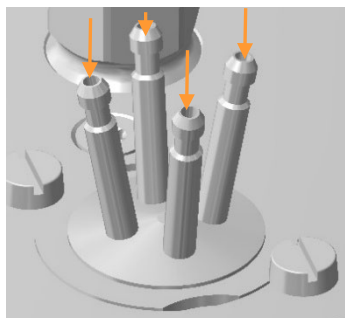

Before Cultivation

2. Attach the silicone hose of the antifoam pump to the mounted antifoam sensor in the culture vessel and secure it with a cable tie.

Connection between reagent bottles and pumps

Proceed as follows:

Procedure

1. Ensure that a hose is fitted inside the reagent bottles at the exposed hose connection (without sterile filter); fit one if not:
 - a) the end of the hose does not touch the bottom of the bottle, otherwise the hose may get sucked against the bottom and no longer be able to pump liquid.
 - b) the end of the hose is cut diagonally. In this case the hose end can touch the bottom of the bottle.
2. Label the reagent bottles in accordance with their content.
3. Depending on the application: Fill the reagent bottles with reagents and reclose them with their lid.



ATTENTION

Usage of the highly corrosive hydrochloric acid HCl as reagent leads to damage to components made of stainless steel such as e.g. component parts or the top plate.

Use only non-corrosive acids, e.g. phosphoric acid, instead.



INFORMATION

Fill reagent bottles with heat-resistant reagents only. Sterilise non-heat-resistant feed solution separately and only transfer it to the reagent bottle after sterilising.

4. Place the reagent bottles in reagent bottle and pump holders.
5. Attach the correct silicone hoses to available hose connections of each reagent bottle and secure them with cable ties.

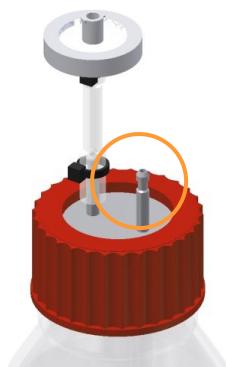

Before Cultivation

6. Close silicone hoses with clamps as close as possible to the hose connections of the reagent bottles to ensure that no reagent can flow into the culture vessel.
7. Ensure that:
 - each reagent bottle is connected with the appropriate pump according to its contents. (Base to base pump, etc.).
 - filters are clean and dry; short hose line is open.
8. Cap the filter loosely with aluminium foil.

8.1.22 Sterile Hose Connections

If additional vessels are needed and these can only be connected to the culture vessel after autoclaving, such as vessels for the inoculum or bottles for sampling etc., rapid couplings (male/female), sterile connectors or – if weldable hoses are used – a hose welding device can be used to form a sterile connection.

The connection pieces must be fitted to the appropriate hoses before autoclaving. Rapid couplings are connected after autoclaving in a sterile workbench. Sterile connectors and hose welding devices allow sterile connecting without a sterile workbench.

8.1.23 Removing the Pump Heads

To remove the pump heads from the basic unit, proceed as follows:

Procedure

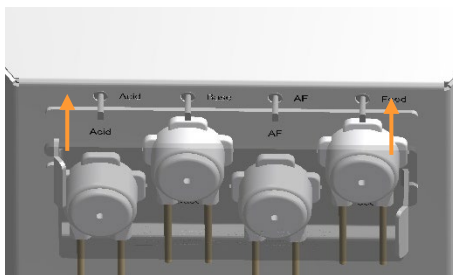

1. Pull up the pump cover plate and remove it from the holder.



INFORMATION

The pump cover plate serves only as a protective device in operating mode. It is not heat proof and therefore it may not be autoclaved.

Before Cultivation

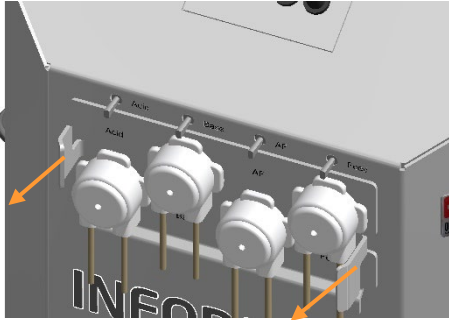

2. Pull the mounting plate with the pump heads off the drive shafts by the two handles.

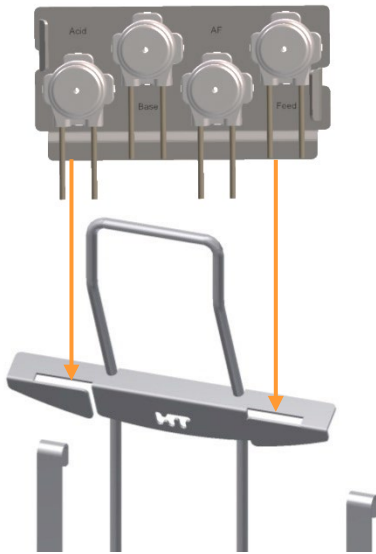

3. Fit the mounting plate with the pump heads onto the reagent bottle and pump holder.

Before Cultivation**8.1.24 Checklist Before Autoclaving**

Check and ensure the following items before autoclaving:

Culture vessel

All necessary O-rings are fitted.

All unused ports are closed with blanking plugs.

Port for inoculation is equipped with septum, septum collar and blanking plug

There is liquid in the culture vessel (autoclavable medium or approx. 10 mL water per litre working volume).

Mechanical seal is lubricated.

Drive hub is lightly capped with aluminium foil.

The water overflow hose of the vessel jacket is open, it is **NOT** kinked or clamped off.

Reagent bottles, hoses and pumps

Reagent bottles are exclusively filled with autoclavable liquids, correctly labelled and connected with the culture vessel and the pump heads via hoses.

Reagent bottles are equipped with filters for pressure equalisation

Reagent bottles are placed in reagent bottle and pump holder and pump heads are placed on the holder with a mounting plate.

Inoculation needles

Inoculation needle is connected to appropriate container for inoculum with a silicone hose.

Inoculation needle is packed in sterile cover or wrapped in aluminium foil.

Super Safe Sampler

The valve group is connected to the dip tube in the culture vessel by means of a hose.

The valve group is lightly capped with aluminium foil.

Sparger and head space gassing

If a sparger with sterile sleeve is used: The sparger is not extended.

The sparger or with head space gassing the port is equipped with a hose and an inlet air filter.

Exit gas cooler

The exit gas cooler is equipped with a new securely fastened exit gas filter.

Before Cultivation

Filters and hoses

All filters are clean, dry and lightly capped with aluminium foil.

There are no open hose ends.

All hose transition points are secured with an autoclavable cable tie or hose clamp to prevent them from slipping.

Hoses on the reagent bottles, for sampling and the gassing system (sparger) are clamped off with hose clamps.

The exit gas hose is **NOT** clamped off.

The hoses are undamaged; the hose lines show no kinks and are not able to kink.

Sensors

All sensors required are mounted and, if necessary, calibrated.

pH sensor is mounted with the probe protection.

Other sensors are mounted with an electrode holder.

The temperature sensor of the autoclave is inserted into the pocket for the temperature sensor of the culture vessel.

pH and pO₂ sensors:

- ANALOGUE: are covered with aluminium foil.
- DIGITAL: are **NOT** covered with aluminium foil.

8.1.25 Autoclaving

Before cultivation starts, the culture vessel is autoclaved in accordance with the application in question. The culture vessel can be autoclaved with or without medium.

Adhere to the following:

- Never autoclave the culture vessel dry; see also the chapter “Moistening/Filling the Culture Vessel”.



INFORMATION

Development of steam is not possible when autoclaving a completely empty and dry culture vessel. Successful sterilisation is not guaranteed.

Ensure that there is liquid in the culture vessel (approx. 10 mL of water per litre of total volume).

- If necessary, pump off any remaining water after autoclaving by means of the dip tube.

Before Cultivation

- Sterilise all liquid, heat-instable components separately and add them after autoclaving.
- If the medium is autoclaved in the culture vessel, you may then need to add sterile water to make up the volume.

When transporting the culture vessel to/from the autoclave, note the following:

- Always transport the culture vessel in the vessel holder.
- Always transport the culture vessel to/from the autoclave in pairs and use suitable auxiliary equipment when transporting the culture vessel.

**WARNING**

Depending on the accessories and fill level, the culture vessel may be too heavy to be carried by one person alone.

Proceed as follows to autoclave the culture vessel:

Procedure

1. Place the culture vessel into the autoclave.
2. Ensure that the culture vessel and the accessories do not touch the inner wall of the autoclave.
3. Ensure that the exit gas filter is open.
4. Insert the temperature sensor of the autoclave into the pocket for the temperature sensor.
5. Select the program for liquids.
6. Autoclave the culture vessel in accordance with the operating manual of the autoclave manufacturer.

Before Cultivation

8.2 Connecting the Culture Vessel and Preparing the Cultivation

As soon as the culture vessel with the accessories has cooled sufficiently, the various cable and tube connections between the basic unit and the culture vessel can be established.

8.2.1 Connecting the Culture Vessel

To connect the vessel to the basic unit, the hoses for water inlet, outlet and overflow of the vessel jacket must be plugged into the appropriate connectors on the basic unit according to the symbols.

i INFORMATION

In order that the hose connections can be disconnected easily after cultivation, slightly moisten the rapid couplings on the silicon hoses prior to connecting them.

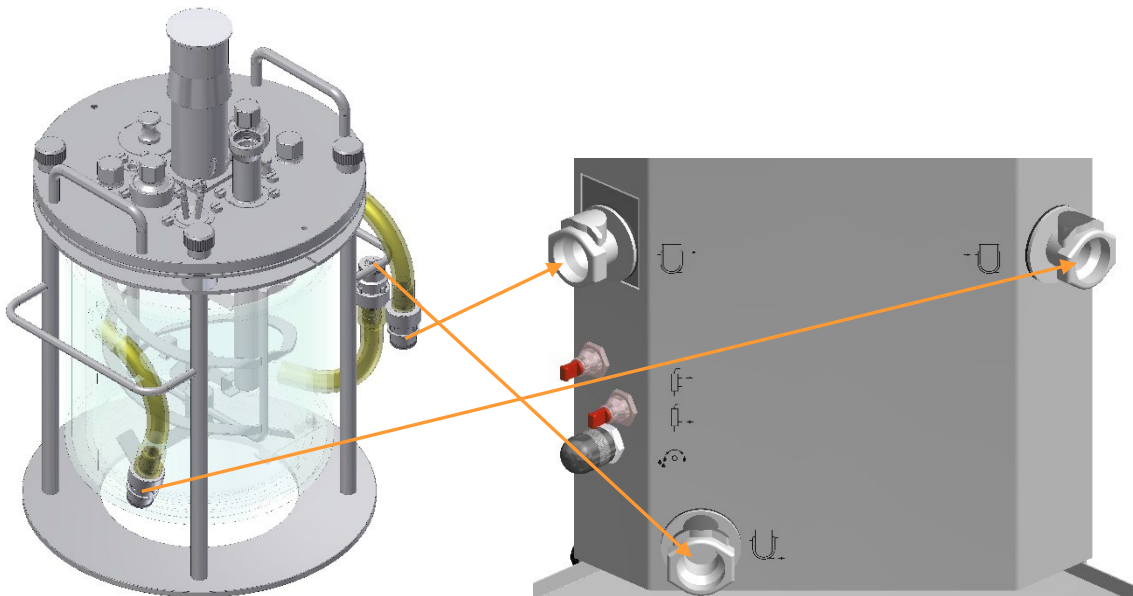

8.2.2 Mounting the Pump Heads

To mount the pump heads to the basic unit, proceed as follows:

Procedure

1. Pull off the mounting plate with the pump heads from the reagent bottle and pump holder.

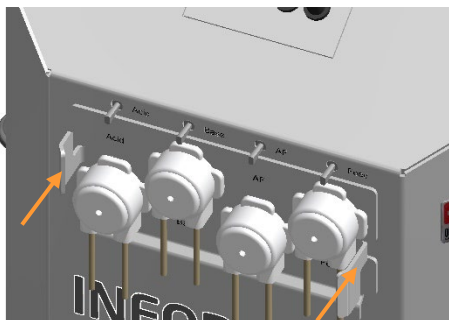

2. Plug the mounting plate with the pump heads onto the pump motor drive shafts.



3. Insert the cover plate into the support.

8.2.3 Filling the Reagent Hoses

In order to prepare the reagent hoses for operation, they must be filled with reagent. This can either be done using the rocker switches of the pumps on the basic unit or via the touch screen software.



INFORMATION

When using several devices at the same time, it is useful and time-saving to fill all reagent hoses simultaneously and automatically.

For details about filling via touch screen software refer to the separate operating manual of the touch screen software.

Before Cultivation

WARNING

When using heavily corrosive reagents (acids and bases), it is particularly important only to use suitable and undamaged hoses. They must also be securely fastened. Furthermore, the exit gas filter must not be blocked. This ensures that no pressure builds up and no reagent escapes due to burst hoses.

Observe the following points:

- Remove the clamps from the reagent hoses, before filling.
- Ensure that no reagent escapes into the culture vessel, if possible.

Filling via rocker switches

Proceed as follows:

Procedure

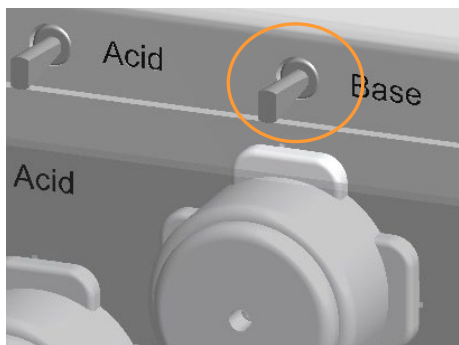

1. Switch the device on at the power switch.
2. Open the clamps on the reagent hoses.
3. Operate the rocker switches and manually fill the reagent hoses one after the other:
 - Press the rocker switch to the right side: the pump runs forward (clockwise), reagent is sucked in from the reagent bottle and is pumped in the direction of the vessel.
 - Press the rocker switch to the left side: the pump runs backwards (counter-clockwise), reagent is liquid is sucked in from the culture vessel and is pumped in the direction of the reagent bottle.

Release the rocker switch just before liquid visibly enters the addition port adapter(s), respectively the dosing needle of the antifoam sensor so that no reagent can enter the culture vessel.

8.2.4 Connecting the Gassing

To connect the sparger to the gassing, proceed as follows:

Procedure

1. Remove the aluminium foil from the inlet air filter.
2. Connect the gassing hose of the basic unit to the inlet air filter of the sparger and secure it with a cable tie.
3. Remove the hose clamp.



INFORMATION

If head space gassing is used, connect its gassing hose to the inlet air filter on the inlet of the addition port adapter.

8.2.5 Connecting the Exit Gas Cooler

To connect the exit gas cooler to the basic unit, proceed as follows:

Procedure

1. Plug the pressure hoses for water inlet and outlet according the symbols on the basic unit into their connectors.

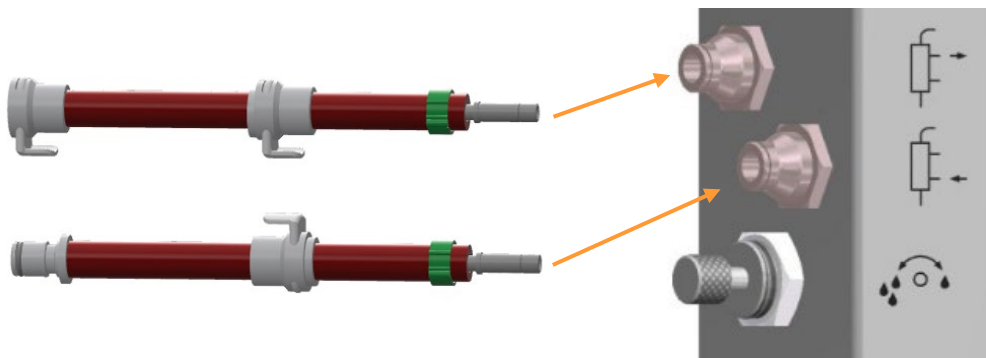

2. Remove the aluminium foil from the exit gas filter.
3. Push the pressure hoses of the exit gas cooler and the basic unit together via the rapid couplings according the symbols on the basic unit.

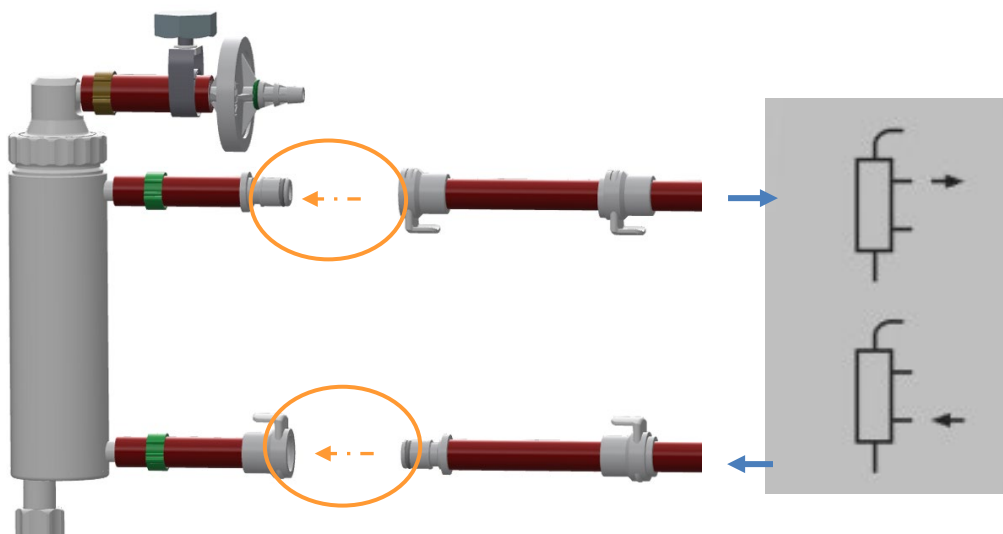

4. If necessary, adjust the standard setting for water flow on the manual valve on the basic unit.

Before Cultivation

The exit gas cooler only works with activated temperature control (Parameter *Temperature* switched *ON*).

i INFORMATION

If no exit gas cooler is used, close the manual valve for water flow on the basic unit or close the hose connectors with the plugs provided with the device.

8.2.6 Coupling the Motor

For routine operation, it is not necessary to plug in and unplug the motor cable. The motor connected during installation is merely connected using a bayonet lock prior to cultivation.

Proceed as follows:

Procedure

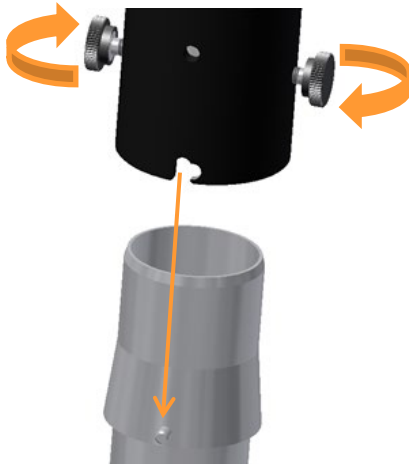

1. Place the motor onto the drive hub with the groove aligned with the pin on the drive hub.

i INFORMATION

The motor houses an O-ring which dampens vibrations. Hence, there is a normal resistance during assembly.

2. Place the screw-mounted pin of the drive hub in the bayonet lock.
3. Turn the motor and thus lock the bayonet lock.
4. Manually tighten the fixing screws.

8.2.7 Filling the Culture Vessel

Depending on the application, the vessel can be filled after autoclaving.

Liquids

Proceed as follows to add sterile liquids:

Procedure

1. Sterilise the medium separately.
2. Ensure that the sparger with the sterile sheath is not extended.
3. If necessary, pump off any water that remains in the culture vessel.
4. Establish a sterile tube connection between the culture vessel and the medium container.

For details see the “Sterile tube connections” section.

5. Pump the desired quantity of medium into the culture vessel.
6. Clamp off the medium tube; if necessary, apply a welded seal.
7. Disconnect the medium container from the culture vessel; if necessary, retain it as a harvest or waste container.



INFORMATION

If the stirrer is turning on the surface of the medium, foam will be formed. For this reason, only switch on the stirrer if it is fully covered by medium.

Viscous or solid medium

To add viscous or solid medium, proceed as follows:

Procedure

1. If necessary, plant the bioreactor in a sterile workbench.
2. Depending on the application, open the 40 mm port or the top plate.
3. Pump off any water that has remained in the culture vessel.
4. Fill the desired quantity of medium into the culture vessel, use a funnel, if appropriate.
5. Close the culture vessel.

Before Cultivation

8.2.8 Inserting the Temperature Sensor (Pt100) into the Immersion Pocket

The temperature sensor is not in direct contact with the medium.

Procedure

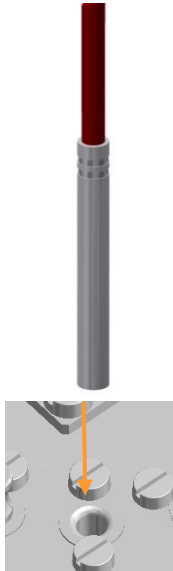

1. Simply insert the sensor into the immersion pocket in the vessel top plate as far as it will go.

CAUTION

Risk of burns and loss of property due to overheating of the temperature control circuit!

The temperature control circuit will overheat without an inserted temperature sensor and without liquid in the vessel. This can lead to burns and loss of property.

8.2.9 Connecting the pH Sensor

The sensor and cable connections of the pH sensors differ depending on the existing pH measurement system:

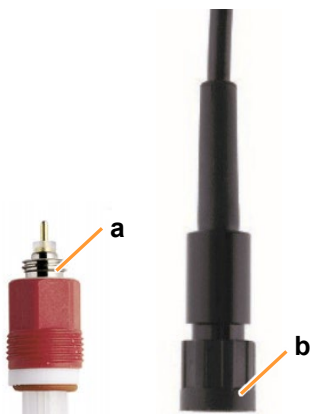

METTLER analogue Type 405-DPAS-SC- K8S/120	Sensor head connection (a)	K8S
	Cable bushing (b)	AK9

! ATTENTION

The sensor cable shield can be damaged by buckling or twisting. This may lead to faulty measurements.

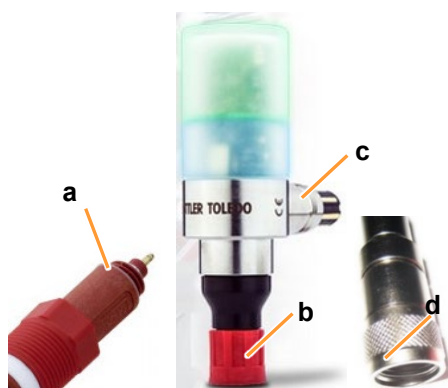

METTLER digital Type InPro 3253i	Sensor head connection (a)	ISM
	Cable bushing (d)	VP8
Head transmitter M100	Plug connection for sensor (b)	
	Plug connection for cable (c)	

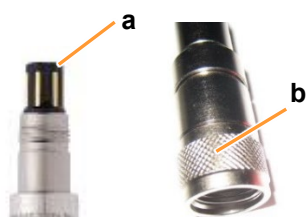

HAMILTON digital Type Easyferm Plus ARC	Sensor head connection (a)	VP8
	Cable bushing (b)	VP8

Before Cultivation

8.2.10 Connecting the pO₂ Sensor

The sensor and cable connections of the pO₂ sensors differ depending on the pO₂ measurement system used:

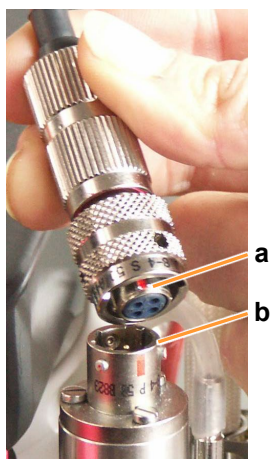

METTLER analogue Type InPro 6820/25/080 (amperometric, polarographic)	Sensor head connection (a)	T-82
	Cable bushing (b)	T-82

! ATTENTION

The sensor cable shield can be damaged by buckling or twisting. This may lead to faulty measurements.

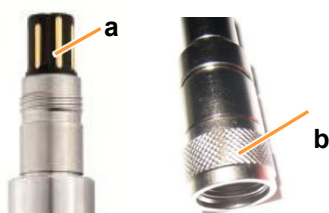

METTLER digital Type InPro6860i	Sensor head connection (a)	VP8
	Cable bushing (b)	VP8

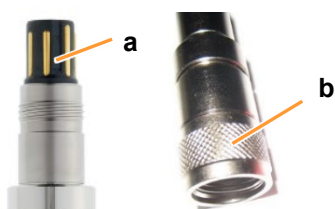

HAMILTON digital Visiform RS485-ECS	Sensor head connection (a)	VP8
	Cable bushing (b)	VP8

8.2.11 pO₂ Sensor (Analogue, Polarographic) Polarisation

Polarographic pO₂ sensors must be polarised at initial operation or after disconnection from the voltage source. Correct calibration is not possible otherwise.

For polarisation, the sensor cable must simply be connected to the pO₂ sensor and the device must be switched on at the main switch.

Duration of polarisation (= polarisation time) depends on how long the pO₂ sensor has been disconnected from the voltage source (= depolarisation time)

As a general rule: if depolarisation time > 30 minutes, the minimum polarisation time is 360 minutes.

More details about polarisation can be found in the separate documentation from the sensor manufacturer.

8.2.12 Calibrating the pO₂ Sensor

A 1-point calibration to 100 % is usually sufficient for exact measurement and should be carried out before each cultivation. If required, a 2-point calibration to 100 % and 0 is also possible.

A detailed description on the calibration can be found in the separate operating manual of the touch screen software.

8.2.13 Checking the Hoses and Hose Connections

Check and ensure the following items before each cultivation:

- Hoses show no kinks and are not able to kink.
- Hoses are undamaged and show no weaknesses.
- Gas hoses and connections do not show any leaks.
- Hose lines are as short as possible.
- Hoses are secured with cable ties and/or hose clamps.
- Only the pressure hoses supplied by the device manufacturer are connected as supply lines (water, gas) between the in-house connections and the device.

Cultivation

9 Cultivation

The following sections describe the work necessary for the performance of and after the completion of a cultivation, before the culture vessel with accessories is thoroughly cleaned and then prepared for another cultivation.

This essentially comprises:

- Preparing the medium, starting the bioreactor
- Sampling
- Inoculation
- Harvest
- Stopping the bioreactor, if necessary emptying the vessel
- Autoclaving the culture vessel and accessories

The requirement for the first item is that the culture vessel and accessories are autoclaved, cooled and connected to the basic unit. All cable and hose connections between the device and the culture vessel, including the reagent bottles, are present, pump heads are mounted and the reagent hoses are filled. Depending on the user specifications, the pO₂ sensor is already calibrated.



INFORMATION

For safety reasons, the maximum permissible rotation speed in the operating software is limited to 300 min⁻¹. The rotation speed limit may only be deactivated and the motor operated at a rotation speed of up to 1000 min⁻¹, if the viscosity of the medium is the same as that of water and no helix impeller is used. For details, refer to the separate operating instructions of the touch screen software.

9.1 Preparing the Medium

Before the first sampling, which usually takes place as a 'zero sample' before inoculation, and before the inoculation itself, the medium must be warmed to the desired temperature. If necessary, the pO₂ concentration and the pH are set. The time required for this depends on the working volume.

Set and activate the desired setpoint of the parameters in question on the operating panel, and start the bioreactor.

Depending on the specifications defined by the user, the pO₂ sensor is calibrated either before the vessel is filled with medium or afterwards, in the prepared medium.

 **CAUTION**

If pressure equalisation does not take place via a top plate opening or the mounted exit gas cooler, overpressure in the culture vessel may occur during cultivation as a result of warming, gassing or fermentation processes.

- Exit gas line - hose at the exit gas cooler with secured exit gas filter - **ALWAYS** keep open.
- Only use clean and dry exit gas filters.

For details about calibration and operation in general refer to the separate operating manual of the touch screen software.

9.2 Sampling

Samples are taken from the culture vessel to gain material for off-line analysis. The method of sampling can vary due to the different analyses carried out by the operator.

The sampling procedure using the standard sampling system, Super Safe Sampler, is described below.

 **INFORMATION**

The Super Safe Sampler is designed only for removing liquid substances. If the medium contains solids, this can clog the hoses or valves. Hence, you should only remove samples of completely liquified medium.

Before starting, observe the following:

 **WARNING**

Culture solution could emerge from the vessel if the sample valve mechanically fails. This could lead to serious health risks in the event of applications with pathogenic organisms.

- When working with pathogenic organisms, always additionally clamp off the sampling hose with a metal (!) clamp.
- Only remove the clamp when sampling.
- Reattach the clamp before removing the syringe from the sample valve.

Cultivation

WARNING

Loose screws at components could lead to the penetration of unsterile air or contamination of the environment.

Before and after autoclaving: Check that all screws are tightly screwed in and, if necessary, tighten them manually.

If the sample is to be further aseptically processed, use a sterile syringe and sterile closing caps.

For details, see the main chapter “Accessories” chapter “Sampling System Super Safe Sampler”, section “Aseptic Sampling”.

Proceed as follows:

Procedure

1. Check that all screw connections of the valve group are tightly screwed in. If necessary, gently tighten the screw connections with two fingers.
2. Remove the clamp from the sampling hose.
3. If present: Remove the closing caps.
4. If desired: Disinfect the sample valve.
5. Screw open the Luer-Lock syringe on the sample valve.



6. Pull back the syringe plunger to remove the desired sampling volume.



If the dip tube was rinsed with air, air is sucked in first. Remove it as follows:

- a) Unscrew the syringe from the valve.
- b) Hold the syringe with the plunger downwards so that the medium remains in the syringe.
- c) Push the air out of the syringe.
- d) Screw the syringe onto the sample valve.
- e) Draw in again.

7. Attach the clamp to the sampling hose.

Rinsing the dip tube with sterile air

The dip tube and its sampling hose can be filled with sterile air after taking a sample.



INFORMATION

Only use a clean and dry syringe to avoid blocking the sterile filter. This syringe can be reused as often as desired, since air is provided via a sterile filter.

To do so, proceed as follows:

Procedure:



1. Insert the syringe onto the hose at the sterile filter and push air through.
The remaining liquid in the hose and in the dip tube is pushed back into the vessel.
2. Remove the syringe from the sterile filter to fill it with air again.
3. Repeat steps 1 and 2 as many times as necessary until bubbles rise out of the dip tube.

Cultivation

Removing residual fluid

To remove residual fluid from the system, proceed as follows:

Procedure:



1. Hold the syringe with sample downwards, pull back the plunger.

This removes all but a few μL of the residual fluid.



2. Hold the sample valve with one hand; unscrew the syringe with the other.

3. If desired: Place the closing caps on the sample valve and on the syringe with the sample.

9.3 Inoculation

Check and ensure the following items before inoculation:

- Medium has been filled.
- Heat-labile, separately sterilised substances are present.
- The reagent bottles are connected to the pumps and the culture vessel and are filled with reagents and nutrient solution enough for the duration of the entire cultivation.
- The hoses of the reagent bottles are filled.
- The correct operating temperature has been reached.
- The required stirring speed is set.

- The sensors are calibrated, and the control is set correctly (maybe not active yet).
- All clamps have been removed (except for sampling system).
- Utensils for the inoculation and vessels with inoculum are ready.

Methods

There are a number of ways to add medium or inoculum before and during cultivation:

- Adding solids through the 40 mm port (not sterile or in a laminar flow cabinet)
- With inoculation needle and septum collar with septum
- In a small volume, with the syringe via the septum
- Via an addition port adapter from the reagent bottle (a sterile hose connection is required for this method).

These methods are described in the following sections.

The implements for inoculation with inoculation needle are standard accessories for the equipment. This inoculation method is particularly suitable for all vessel sizes of the equipment. If separate addition of several different solutions is necessary, a second inoculation needle can be used with mounted septum collar in a spare port.

9.3.1 Inoculation with Inoculation Needle

Proceed as follows for inoculation:

Procedure

1. Fill the inoculum under sterile conditions into the prepared container.
2. Unscrew the blanking plug from the septum collar.
3. If appropriate, place a few drops of Ethanol (70 %) on the septum before piercing the septum.
If appropriate, briefly flame the septum collar.
4. Remove sterile cover/aluminium foil from the inoculation needle.
5. Briefly flame the inoculation needle.

Cultivation

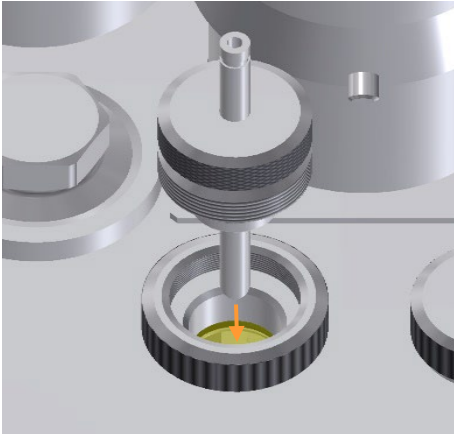

6. Immediately pierce the inoculation needle through the septum.

7. Screw the inoculation needle into the septum collar.
8. Transfer the desired volume of inoculum into the culture vessel.
9. Clamp off the silicone hose.
Or: Pull the inoculation needle out and close the septum collar with the blanking plug. But this method is not secure regarding preventing contamination.

9.3.2 Inoculation with a Syringe

Proceed as follows for the inoculation:

Procedure

1. Fill the syringe with the required amount of inoculum.
2. Unscrew the blanking plug from the septum collar.
As a possible additional protection against contamination:
Before piercing, drop a few drops of ethanol (70 %) on the septum.
3. Pierce the septum and inject the inoculum.
4. Remove the needle from the septum and close the septum collar with a blanking plug.

9.3.3 Inoculation Using Dip Tube / Addition Port Adapter

Proceed as follows during inoculation:

Procedure

1. Fill the inoculum under sterile conditions into the prepared container.
2. Create a sterile hose connection with the dip tube/addition port adapter.
3. Transfer the desired volume of inoculum into the culture vessel. Pump it, if necessary.
4. Clamp off the hose by means of a clamp, weld it if necessary.

9.4 Extending the Sparger with the Sterile Sheath

To prevent the sparger from clogging up due to solids in the medium, the sparger is covered by a sterile sheath. Once the medium is liquified, the sparger can be extended and gassing can start. To do so, proceed as follows:

i INFORMATION

Gassing may only be started once the sparger is extended.

Procedure

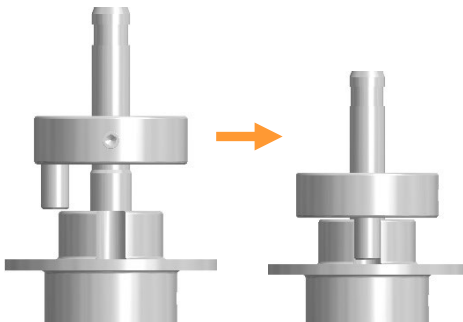

1. Turn the screw-mounted pin on the hand ring using the indentation in the sterile sheath cover.
2. Push the hand ring down to the stop.
3. Start gassing. Depending on the gassing strategy chosen, either open the rotameter(s) or set the corresponding flow parameters in the touch screen software. For more information, refer to the separate operating instructions of the touch screen software.

9.5 Harvest

The culture can be harvested at the end of the cultivation. To prevent possible sedimentation from the culture, the stirrer can be switched on during harvesting. If necessary, activate gassing for sensitive cultures. However, all other parameters should be switched off, provided there are no other specifications for the user.

The following possibilities exist for the harvest:

- a) Transfer to another vessel
To transfer the contents of the vessel to another container in a laminar flow cabinet.
- b) Pump-down via a sterile hose connection
To do so, proceed as follows:

Procedure

1. Make a sterile connection between the hose at the dip tube for harvest and the new vessel.
2. Connect the hose to one of the pumps on the device or to an external pump.
3. Pump the desired amount of culture into the new vessel.

Cultivation

INFORMATION

Only switch on the stirrer, if it is fully covered by medium, as foam otherwise forms.

4. Switch off all parameters on the operating panel, i.e. stop the bioreactor.

ATTENTION

Switching the device off at the power switch without stopping the bioreactor and shutting down the system on the operating panel beforehand may lead to damage of the operating panel!

9.6 Emptying the Culture Vessel

Depending on the user specifications, the culture vessel can be emptied either before or after autoclaving.

A previously emptied and culture vessel filled only with water for autoclaving is easier to clean afterwards.

For emptying the culture vessel, the same options as for harvesting are available. For more information, see chapter “Harvest”.

If the culture will not be used further, it must be inactivated according to the current in-house instructions (e.g. by autoclaving or by lowering the pH value), and subsequently disposed of in an environmentally sound manner according to the local regulations.

9.7 Emptying the Reagent Hoses

ATTENTION

Residues of acids and alkalis in the reagent hoses during autoclaving can damage the pump heads.

- Completely empty all reagent hoses before autoclaving.
- Thoroughly rinse the reagent hoses with water after emptying.

Before autoclaving the culture vessel with accessories, all reagent hoses must be completely emptied via the corresponding pump. This can either be done using the rocker switches of the pumps on the basic unit or via the touch screen software.

**INFORMATION**

When using several devices at the same time, it is useful and time-saving to empty all reagent hoses simultaneously and automatically.

For details about emptying via touch screen software refer to the separate operating manual of the touch screen software.

9.8 Switching off the Device

When the harvest is finished or the culture vessel has been emptied and the reagent hoses are also empty, the device can be switched off.

Proceed as follows:

Procedure

1. Ensure that the bioreactor has been stopped. If necessary, stop it in the touch screen software on the operating panel.
2. Shutdown the system on the operating panel.
3. Switch off the device at the power switch.

**ATTENTION**

Switching the device off at the power switch without previously stopping the bioreactor and shutting down the system on the operating panel may lead to damage of the operating panel!

4. Close the supply lines (water, gas).
5. Let the motor cool down.
6. Autoclave the vessel, built-in parts and accessories as per the user-specific specifications and then clean them.

Cultivation

9.9 Autoclaving the Culture Vessel after Cultivation

After emptying the culture vessel and before cleaning, the culture vessel must be autoclaved with all accessories. When doing so, do not autoclave the culture vessel when completely dry and observe the same safety regulations as when autoclaving before cultivation.

Before starting, ensure:

- There is liquid in the culture vessel (autoclavable medium or approx. 10 mL water per litre working volume).
- Reagents and nutrient solution have been pumped back out of the hoses.
- The device is switched off.
- The motor has cooled down.

Proceed as follows to prepare the culture vessel and accessories for autoclaving after cultivation:

Procedure

1. Clamp off the hoses of the reagent bottles.
2. Clamp off the sparger hose or the hose for head space gas-sing.
3. Remove all cable and hose connections between the basic unit and the culture vessel:
 - a) Uncouple the motor and place it to the side.
 - b) Unplug the sensor cables.
 - c) Pull the temperature sensor out of the immersion pocket.
 - d) If an exit gas cooler is in use: disconnect the water inlet and water outlet hoses from the exit gas cooler.
 - e) Disconnect the water inlet / outlet /overflow hoses of the vessel jacket from the basic unit.
 - f) Depending on the gassing strategy:
 - Remove the gassing hose (emerging from basic unit) from the inlet air filter on the sparger.OR:
 - Remove the heads space gassing hose (emerging from the basic unit) from the inlet air filter on the addition port adapter.
4. Lightly cover all filters and the drive hub with aluminium foil.



ATTENTION

DIGITAL pH and pO₂ sensors: **DO NOT** cover with aluminium foil!

5. Open the pump cover.
6. Remove the mounting plate with pump heads from the drive shafts on the basic unit and place on the pump holder.
7. Check and ensure that the exit gas filter is free and dry and the exit gas hose is **OPEN**.
8. Insert the temperature sensor of the autoclave into the immersion pocket on the culture vessel and autoclave the culture vessel.

Cleaning and Maintenance

10 Cleaning and Maintenance

The following sections describe in detail how the culture vessel and accessories and the basic unit are cleaned and, as required, stored.

In addition, the section contains a maintenance plan and corresponding descriptions for the procedures to be performed by the operator.

10.1 Cleaning Agent and Disinfectant

Intended use	Allowed products/tools
Culture vessel	Water and a non-scratch, non-abrasive sponge or washing-up brush; lab washer with special washing agent (for industry and lab use)
Cleaning agent for denaturation of proteins	0.1 N NaOH
Cleaning agent for smaller component parts	Ultrasonic bath
Cleaning agent for surfaces	Water
Disinfectant for surfaces	Ethanol, 70 %
Decalcifier for the device	Amidosulfonic acid (in liquid form)

10.2 Cleaning the Culture Vessel - Routine Cleaning

The culture vessel and accessories can be cleaned as soon as they have cooled down after autoclaving.



ATTENTION

Household washing-up liquid and soap (in particular cream soaps) can collect in glass pores and impair later cultivations.

Never clean culture vessels and accessories with household soap and use special cleaning agent (for industrial and lab use) in the lab washer.

The following method describes a routine cleaning between two cultivations. It takes place with the culture vessel completely assembled and the accessories completely mounted.

Cleaning and Maintenance

This does not include the sensors, with the exception of antifoam or level sensors from the device manufacturer. To avoid damaging the other sensors during the routine cleaning, they are first removed and then cleaned separately according to the third-party manufacturer guidelines and then stored, if necessary. Also see the “Removing Sensors” section and “Cleaning Sensors”.

Proceed as follows to carry out a routine cleaning of the culture vessel:

Procedure

1. Carefully unscrew the sensors by hand (no tools!) from the vessel top plate ports and place them to the side for separate cleaning according to the manufacturer guidelines.
2. Completely fill the culture vessel with 0.1 N NaOH.
3. Fit the top plate on the vessel and secure it.
4. Connect the culture vessel to the basic unit.
5. Couple the motor.
6. Switch on the equipment at the power switch.
7. At the operating panel in the touch screen software, start the bioreactor and stir strongly for 2 hours with the stirrer function (parameter *Stirrer*).



INFORMATION

It is recommended to warm the 0.1 N caustic soda to 60 °C and to prolong the duration of stirring for dealing with persistent residue of foam or protein.

8. Stop the bioreactor in the touch screen software at the operating panel.
9. Shutdown the system at the operating panel.
10. Switch off the equipment at the power switch.
11. Let the motor cool down.
When the motor has cooled down:
12. Uncouple the motor.
13. Remove the top plate and carefully place it so that it does not(!) lie on top of components.
14. Empty the culture vessel.
15. Thoroughly rinse the culture vessel with distilled water.

Cleaning and Maintenance

10.3 Removing the Vessel Top Plate and Accessories

All accessories must be removed for thorough cleaning of the individual parts of the culture vessel. This is described in the following sections. The cleaning itself is described in the chapter “Cleaning and Storing Individual Parts”.

The cleaning of the hoses with pump heads, the basic unit and the operating panel are described in separate sections.

Sensors from third-party manufacturers are cleaned according to their manufacturer’s specifications.

10.3.1 Removing the Exit Gas Cooler

To remove the exit gas cooler, proceed as follows:

Procedure

1. Unscrew the exit gas cooler from the vessel top plate port by hand.
Ensure that the O-ring does not get lost.
2. Remove the pressure hose with exit gas filter, dispose of the exit gas filter.
3. Unscrew and remove the coupling nut on the lid by hand in counter-clockwise direction.

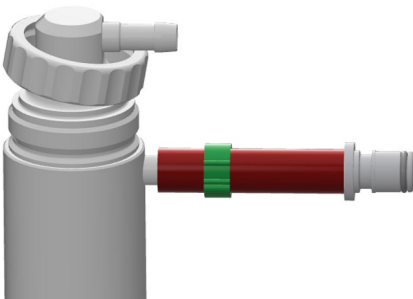

4. Remove the lid by hand.
If necessary, wet the lid slightly with water to facilitate loosening of the lid.

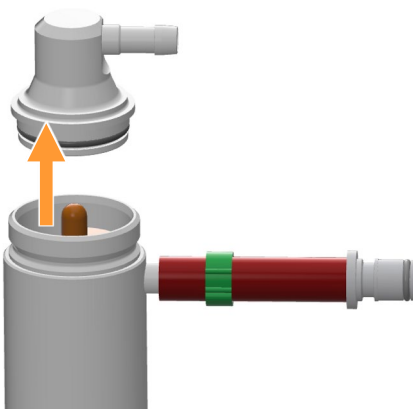

Cleaning and Maintenance

5. Remove the silicone baffle from the exit gas cooler.

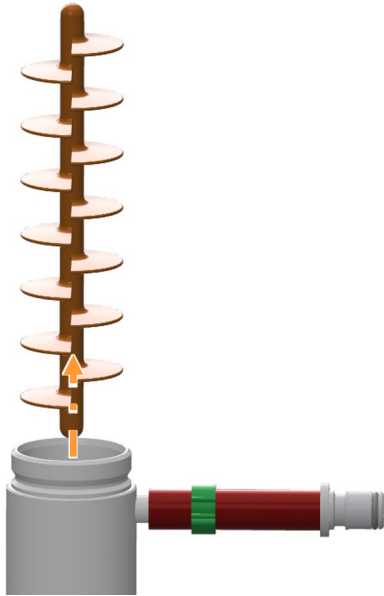

6. Clean the individual parts of the exit gas cooler. For details on cleaning, see chapter "Cleaning and Storing Individual Parts".

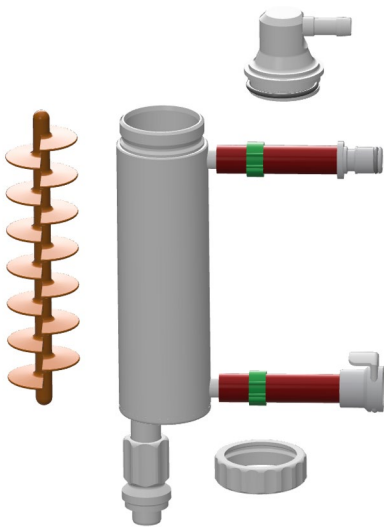

10.3.2 Removing the Sensors

Sensors are either mounted directly into the ports or by means of a sensor holder or clamping adapter. For removal of the sensors, proceed as follows:

Sensor without holder/clamping device

Procedure

1. Carefully unscrew the sensor by hand (no tools!) from the vessel top plate port.

Cleaning and Maintenance

Procedure

Sensor with sensor holder

1. Carefully loosen and unscrew the sensor on the hollow screw of the sensor holder from the port by hand.
2. Carefully unscrew the sensor from the guide bar and gently pull it out of the sensor holder.

Procedure

Sensor with clamping adapter (antifoam and level sensor)

1. Loosen both slotted screws next to the sensor in the port.



INFORMATION

This step is only necessary for the type of clamping adapter for 10 mm ports. All other clamping adapters can be directly unscrewed and pulled out from the port or threaded adapter in the port by hand.

2. Carefully pull the clamping adapter together with the sensor out of the port / threaded adapter in the port.
3. Ensure the O-ring of the clamping adapter does not get lost.
As required:
4. Depending on the type of clamping adapter, loosen the slotted screw or the hollow screw and carefully pull the sensor out of the clamping adapter by hand.
5. Ensure that the insulation on the sensor does not get damaged.

10.3.3 Removing Hoses, Filters and Pump Heads

To later clean reagent hoses and pump heads, they must be removed from the reagent bottles and from components of the culture vessel.



INFORMATION

To avoid damage, never dismantle the pump heads. Always replace a damaged pump head along with the pump hose, and vice versa.

Proceed as follows:

Procedure

1. Remove cable ties (e.g. with a side cutter) so that the hoses are not damaged.
2. Pull hoses off the culture vessel and the reagent bottles.

Cleaning and Maintenance

3. Remove and dispose of filters for pressure equalisation and hoses from reagent bottles.
4. Ensure that the inlet air filter is clean, dry and not blocked. If this is not the case, dispose of it.



INFORMATION

If the filter for pressure equalisation and the corresponding hoses have been used several times, ensure that the filters are always dry and clean.

5. Dispose of the exit gas filter (see also chapter "Removing the Exit Gas Cooler").

10.3.4 Removing Blanking Plugs

Proceed as follows:

Procedure

Blanking plugs in 10/40 mm ports

1. Loosen both slotted screws next to the blanking plug in the port.
Ensure the screws do not get lost.
2. Pull the blanking plug out of the port by hand.
Ensure that the O-ring on the blanking plug does not get lost.

Procedure

Blanking plugs in 12 mm/Pg13.5 ports

1. Loosen the blanking plug with the hexagon socket spanner and remove it by hand.
Ensure that the O-ring does not get lost.

Procedure

Blanking plugs in 19 mm ports

1. Loosen the blanking plug with the hexagon socket spanner in the threaded adapter in the port and remove it by hand.
Ensure that the O-ring does not get lost.

Cleaning and Maintenance

10.3.5 Removing Threaded Adapters

Proceed as follows:

Procedure

1. Loosen both slotted screws next to the threaded adapter in the 19 mm port.
Ensure the screws do not get lost.
2. Remove the threaded adapter.

10.3.6 Removing the Inoculation Needle, Septum Collar and Septum

Proceed as follows:

Procedure

1. Unscrew the inoculation needle from the septum collar by hand.
Ensure that the O-ring does not get lost.
2. Unscrew the septum collar out of the port or threaded adapter (in 19 mm port) by hand.
3. Remove the septum from the port and dispose of it.

10.3.7 Removing Addition Port Adapters

Proceed as follows:

Addition port adapter, quadruple, in 19 mm port

Procedure

1. Loosen the two slotted screws next to the addition port adapter.
Ensure the screws do not get lost.
2. Remove the addition port adapter.
Ensure the O-ring on the adapter does not get lost.



INFORMATION

The removal procedure of further models of addition port adapters (refer to main chapter “Accessories” for details) is the same as for blanking plugs in their corresponding ports. That is why their removal is not repeatedly described here.

10.3.8 Removing the Vessel Top Plate

Proceed as follows to remove the vessel top plate:

Procedure

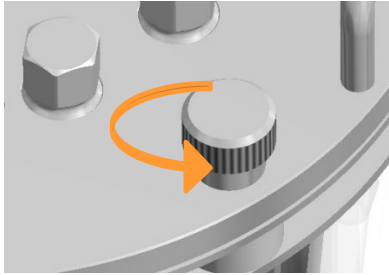

1. As far as possible, remove mounted parts before lifting the top plate.
2. Loosen and remove the knurled nuts on the top plate by hand (no tool!) and place them to the side.

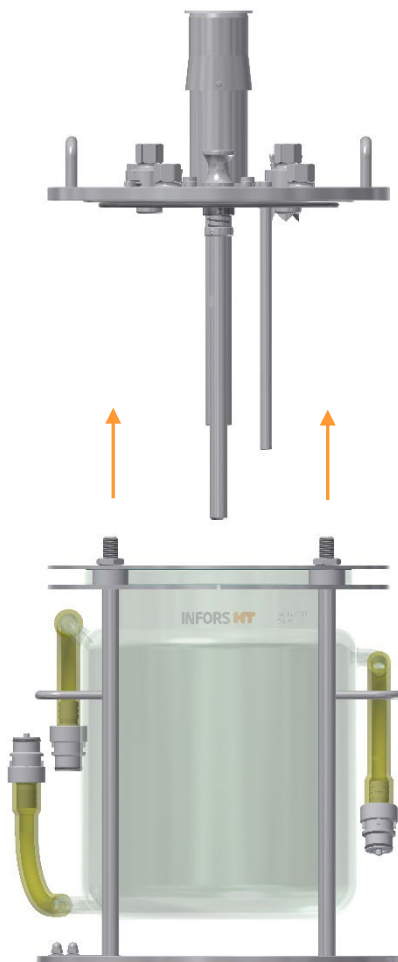

3. Carefully lift the top plate vertically upwards from the vessel until the stirrer shaft and other long built-in components can no longer come into contact with the glass vessel.

Cleaning and Maintenance



ATTENTION

If the vessel top plate presses against long components such as the stirrer shaft etc., they could bend because of the weight of the top plate.

Always position the vessel top plate so that it does not lie on top of components.

4. If necessary, now remove components that have not yet been removed.
5. Check the glass vessel for damage (cracks, fissures, scratches) and replace if necessary.

10.3.9 Removing the Immersion Pocket for Temperature Sensor (Pt100)

Proceed as follows:

Procedure

1. Loosen both slotted screws next to the port.
Ensure the screws do not get lost.
2. Push the immersion pocket from the inside of the vessel top plate up, so that it can be pulled out of the port from the outside of the top plate.
Ensure the O-ring on the immersion pocket does not get lost.

10.3.10 Removing the Sparger and the Dip Tube(s)

Straight spargers and dip tubes can be removed from the outside of the vessel top plate. Curved spargers and dip tubes can only be removed from the inside of the vessel top plate.

Since this equipment uses ring spargers and straight dip tubes, removal from the inside of the vessel top plate is described here. This means that the vessel top plate is already removed.

Proceed as follows:

Procedure

1. Loosen the slotted screw on the clamping adapter.
2. Carefully pull the sparger/dip tube from the bottom out of the clamping adapter.
3. Unscrew the clamping adapter out of the port by hand.
Ensure that O-ring does not get lost.

Cleaning and Maintenance

Dismantling the sparger with the sterile sheath for cleaning

Procedure

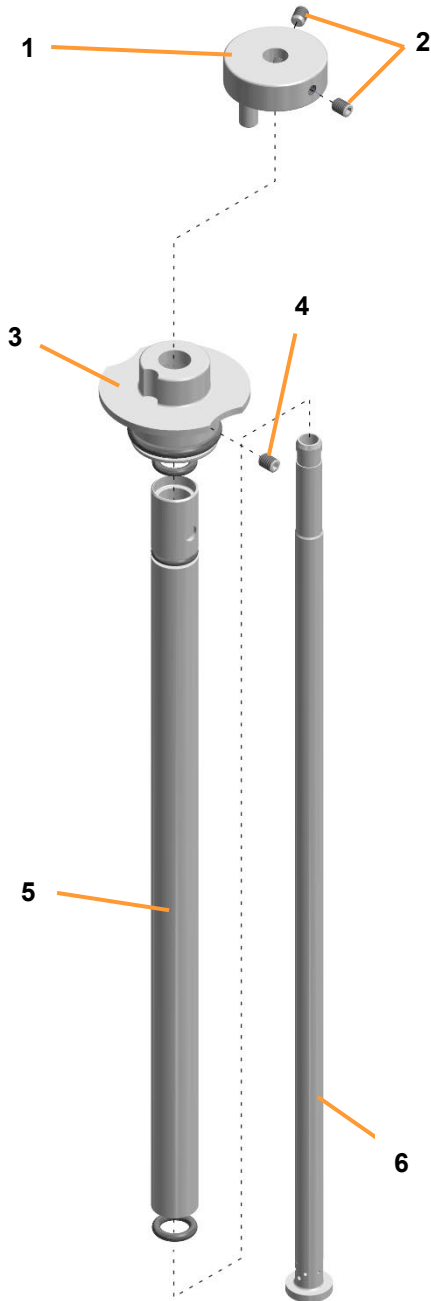

1. Loosen the grub screw on the hand ring (2) (do not remove it).
2. Pull the hand ring (1) off the sparger.
3. Loosen the grub screw on the sterile sheath cover (4) (do not remove).
4. Pull the sterile sheath cover (3) off the sterile sheath (5).
5. Remove the O-ring from the sterile sheath.
6. Pull the sparger (6) from the bottom out of the sterile sheath.

Cleaning and Maintenance

10.3.11 Removing the Impellers

Before removing the impellers, it is recommended to measure and record the positions to aid later mounting.

Proceed as follows to remove:

Procedure

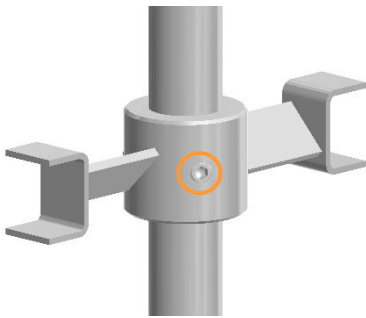

1. Loosen the grub screws on the impeller with an Allen key – do not remove!

2. Carefully remove the impeller from the stirrer shaft.

10.3.12 Removing the Stirrer Shaft

If needed, the stirrer shaft can be removed for cleaning. Particular care shall be taken, to do so.



ATTENTION

The mechanical seal is sensitive to applied forces. Manipulation on it may lead to its damage!

To remove the stirrer shaft from the vessel top plate, proceed as follows:

Procedure

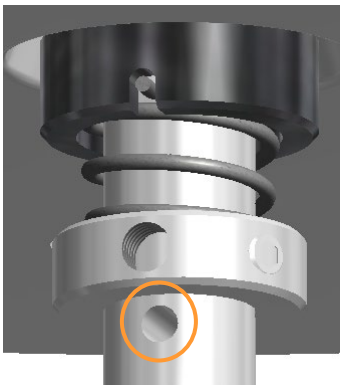

1. Insert an Allen key or a thin metal bar into the opening on the upper end of the stirrer shaft.

This locks the stirrer in its position.

Cleaning and Maintenance



2. Position an adjustable spanner on the two recesses on the upper end of the stirrer shaft.



3. Unscrew the stirrer shaft with the spanner counter-clockwise from the drive shaft.
4. Check the O-ring on the drive shaft for damages, replace as necessary.

10.4 Removing the Glass Vessel from the Holder

The glass vessel and the individual parts of the vessel fixation in the vessel holder may also be cleaned individually in the event of heavy soiling or if internal regulations so require. For this purpose, the glass vessel must be removed from the holder.

Proceed as follows:

Procedure

1. Remove the silicone hoses from the glass olives for water inlet, outlet and overflow of the vessel jacket.
2. Remove the top plate seal (O-ring).

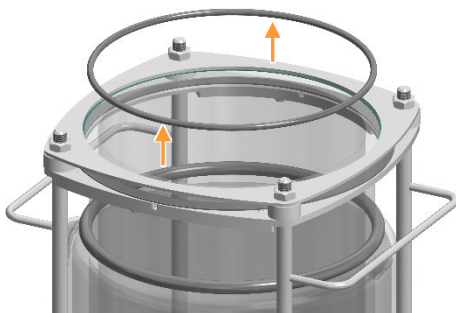

Cleaning and Maintenance

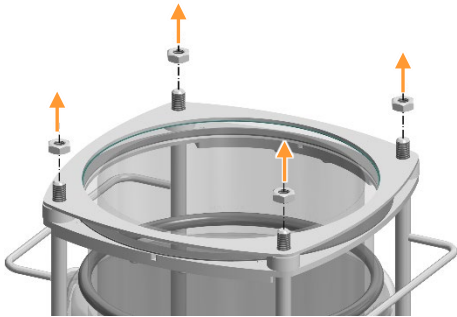

3. Loosen and remove the four lock nuts on the stainless steel ring by hand.

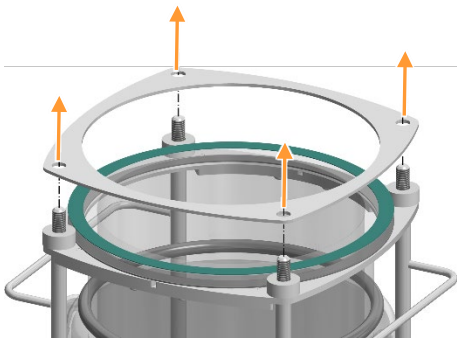

4. Remove the stainless steel ring.

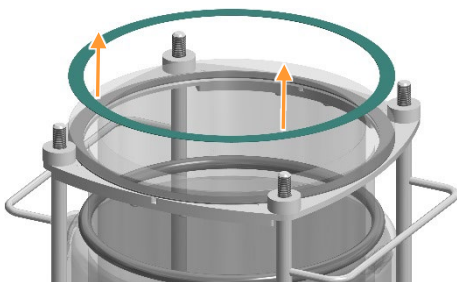

5. Remove the green shock-absorbing ring from the vessel collar.

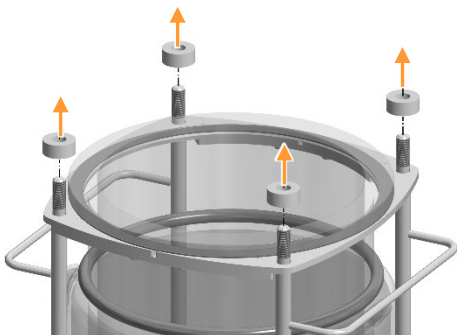

6. Remove the white spacers from the rods of the vessel holder.

Cleaning and Maintenance

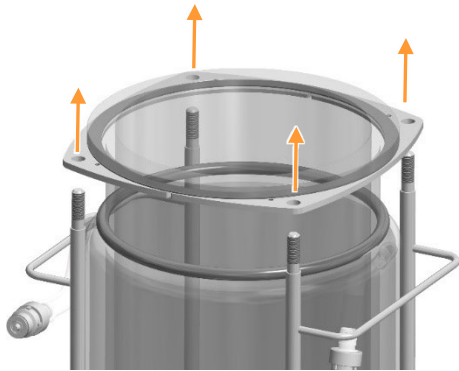

- Lift the glass vessel out of the holder on the two-piece flange by pulling it off the rods of the holder.



- Remove the two-piece vessel flange.

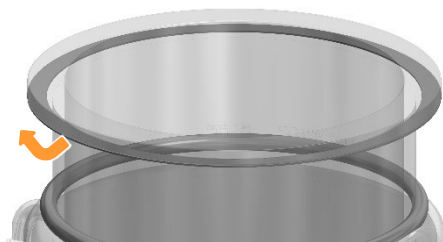

- Remove the black shock-absorbing ring from the vessel collar.

- Clean the vessel and individual parts.

10.5 Cleaning and Storing Individual Parts

The procedure described here applies to the following individual parts:

- Vessel
- Exit gas cooler
- Accessories such as blanking plugs, spargers, dip tubes, addition port adapters etc.
- Reagent bottles
- Vessel top plate, with regard to its particular characteristics

Cleaning and Maintenance

Particulars when cleaning the top plate

- Do not place the top plate on the stirrer shaft (if stirrer shaft is not removed).
- Never remove the drive hub and the mechanical seal! This may only be carried out by qualified personnel.
- **NEVER** clean the vessel top plate in the dishwasher!



ATTENTION

The mechanical seal is very delicate. No water/cleaning agent may enter it and the silicone hose on the bottom of the drive hub may not be pulled off during cleaning of the vessel top plate.



INFORMATION

Cleaning of the sensors, hoses and pump heads as well as the basic unit are described in separate sections.

Proceed as follows for cleaning:

Procedure

1. Clean parts with distilled water and a soft sponge or in the dishwasher (except for the vessel top plate!).
Ensure that the deposits in the dip tubes and in the exit gas cooler are removed. Use 0.1 N caustic soda solution followed by distilled water as necessary. For this, see chapter "Cleaning the Culture Vessel".
2. Dry all parts, including the inner parts of the dip tubes and sparger, as well as the exit gas cooler and its hoses for water inlet/outlet.
3. Check all O-rings for cracks or damage. Replace them if necessary.
4. Store the vessel, vessel top plate and accessories in a clean, dry state in a location where they cannot be physically damaged (e.g. by falling), or prepare them for the next cultivation.

Cleaning and Maintenance

10.6 Cleaning the Sensors

Apart from antifoam and level sensor, all sensors are cleaned and maintained according to the descriptions of the sensor manufacturer.

Procedure

1. Clean the sensors according to the sensor manufacturer guidelines.
2. Prepare the sensors for the next cultivation or, if necessary, service and/or store them according to the sensor manufacturer guidelines.

10.7 Cleaning the Hoses and Pump Heads

Proceed as follows to clean the reagent hoses and pump heads:

Procedure

1. Thoroughly rinse the hoses with the pump heads with water.
2. Carefully dry all hoses and, if necessary, blow out with clean-compressed air.



INFORMATION

To avoid damage, never dismantle the pump heads. Always replace a damaged pump head along with the pump hose, and vice versa.

10.8 Cleaning the Super Safe Sampler



ATTENTION

Risk of damage to the sampling system from unsuitable cleaning methods or cleaning agent (such as acids, bases or solvents, for example).

- Only use water or a mild soap solution for cleaning.
- The sterile filter must remain dry at all times.

Proceed as follows to clean the sampling system:

Procedure

1. Fill the culture vessel with water or a mild soap solution.
Or: Remove the sampling hose from the dip tube and hold it in a vessel, e.g. a beaker, with water or a soap solution.

Cleaning and Maintenance

2. Place the syringe on the automatic valve and pull out the plunger to rinse the sampling system.

When using a soap solution:

3. Then rinse the sampling system thoroughly with water.



INFORMATION

If the test record requires that the culture is killed off after cultivation by autoclaving the culture vessel, the valves of the sampling system may become stuck due to residue of the culture solution. In such a situation, it would be better to autoclave the sampling system separately in a beaker of water (hoses filled with water, filter removed).

10.9 Cleaning the Basic Unit and Operating Panel

Proceed as follows to clean the surface of the basic unit and the operating panel as required:

Procedure

1. Switch off the device at the power switch.
2. Disconnect the device from the power supply.
3. Wipe all surfaces with a damp cloth.
Clean with an appropriate disinfectant as necessary.
4. Clean the screen with a wipe suitable for computer or laptop screens.

10.10 Maintenance Plan



WARNING

Non-compliance of this maintenance plan contains a high risk!

It is the responsibility of the user, that this maintenance plan is complied with. Non-compliance will lead to exclusion of liability (see General Terms and Conditions).

The required maintenance for reliable operation is described in the following chapters.

Reduce the maintenance intervals in case increased abrasion is detected during regular checks.

Contact the manufacturer for questions concerning maintenance.

Cleaning and Maintenance

To be carried out by operator

Interval	Maintenance work
Before each cultivation	Check all hoses and hose connections. Replace hoses, if necessary. Supply hoses may be replaced by qualified personnel.
	Check cables for damage and kinks.
	Check all O-rings and seals and replace if necessary.
	Check the integrity of all glass parts (vessel, reagent bottles) and replace if necessary.
	Check all filters and replace if necessary. Replace the exit gas filter.
	If necessary, calibrate the sensors.
	Check lubrication of mechanical seal and lubricate as necessary.
After every cultivation	Autoclave and clean the culture vessel and accessories.
As required	Clean the basic unit and operating panel.
	Decalcify the device via the vessel jacket.

To be carried out by qualified personnel

Interval	Maintenance work
Every 6 months	Check functionality of measurement sections (temperature, pH, etc.), use simulator, where possible.
As required	Replace supply hoses.

To be carried out by operator, ONLY AFTER CONSULTATION OF MANUFACTURER

Interval	Maintenance work
As required	Decalcify the device.

To be carried out by INFORS HT service technician

Interval	Maintenance work
Annually (recommendation)	Full maintenance of the device.

Cleaning and Maintenance

10.11 Lubricating the Mechanical Seal

The two-part silicone hose on the drive hub must always be filled with liquid (Glycerine, for detailed information see main chapter “Technical Data”, chapter “Operating Materials”) to ensure the mechanical seal is lubricated.

ATTENTION

Risk of loss of property due to the mechanical seal running dry!

A mechanical seal, which has not been adequately lubricated, is destroyed when running dry.

Proceed as follows for lubrication:

Procedure

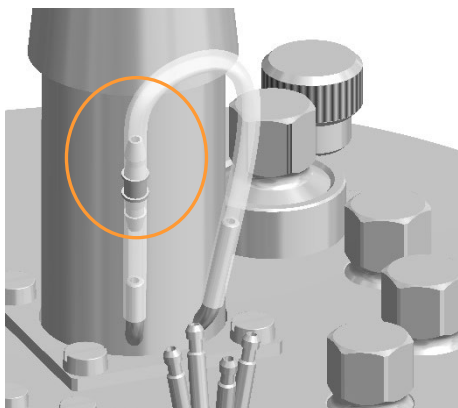

1. Pull off the longer piece of hose from the coupling on the shorter piece.
2. Fill a syringe with glycerine and plug it onto the open hose end.
3. Fill Glycerine into the hose.
4. Plug the longer piece of hose onto the coupling of the shorter piece.
If Glycerine has come off the tubing, wipe off as necessary.

Cleaning and Maintenance

10.12 Decalcifying the Device

Calcification could block mounting parts, lines or valves in the basic unit. It may be necessary to decalcify the device if certain faults occur in the temperature control system.

Note the following points, before begin of the procedure:



ATTENTION

Inappropriate decalcifying of the device may lead to loss of property.

Only decalcify the device **AFTER CONSULTATION** of the manufacturer or licensed dealer!



INFORMATION

A turbid or milky coloured appearance of the glass of the vessel jacket may be a sign of lime scale in the device. A first possibly already sufficient procedure may be to decalcify the device via the vessel jacket. Refer to chapter "Decalcifying the Device via Water Jacket" for details in this case.

- Be sure to respect the in chapter "Technical Data" specified inlet pressure.
- To warm up the decalcifier and pump it into the basic unit, use a chiller or a water bath and an external pump.
- During decalcification, the decalcifier flows in a circuit between the basic unit and the chiller/water bath.
- Use amidosulfonic acid in liquid form as decalcifying agent.



ATTENTION

Amidosulfonic acid can crystallise in case of overdosage and cause loss of property!

When preparing the decalcifying liquid, observe and follow the manufacturer's instructions for correct dosage and application!

- For the mixture, calculate 5 litres of water plus the capacity of the water bath/chiller including the hoses.

Cleaning and Maintenance

Proceed as follows for decalcifying:

Procedure

1. If applicable, mount the exit gas cooler into the port of the vessel top plate and connect to the basic unit.
2. Connect the culture vessel to the basic unit.
3. Let the water drain off from the water outlet on the basic unit.
4. Fill the chiller/water bath with the prepared decalcifying liquid.
5. Connect the chiller or water bath to the water inlet and outlet on the basic unit.
6. To open the corresponding valves in the basic unit, set the temperature on the operating panel to 5 °C (cool).
7. Set the chiller/water bath to 20 °C to 40 °C.
8. Switch on the pump at the chiller/water bath.
9. Let the decalcifier flow through the device for an hour.
10. Connect the water inlet hose on the device to tap water.
11. Hang the water outlet hose of the device at the spout.
12. Rinse the device for an hour.

10.13 Decalcifying the Device via Vessel Jacket

A turbid or milky coloured appearance of the glass of the vessel jacket may be a sign of lime scale in the device. A first possible procedure may be to decalcify the device via the vessel jacket.

If there are still some interferences observed with the temperature control system after doing so, then a thorough decalcification of the device may be necessary. Refer to chapter “Decalcifying the Device” in this case.

Prepare the following things and note the following points before begin of the procedure:

- Prepare a funnel and piece of hose for connection to the water overflow of the vessel jacket.
- Be sure to respect the in chapter “Technical Data” specified inlet pressure.
- Use amidosulfonic acid in liquid form as decalcifying agent.

Cleaning and Maintenance**ATTENTION**

Amidosulfonic acid can crystallise in case of overdosage and cause loss of property!

When preparing the decalcifying liquid, observe and follow the manufacturer's instructions for correct dosage and application!

- Prepare a mixture with 5 litres of water. This amount of liquid covers in any case the vessel jacket volume including the volume of the temperature control unit in the basic device.

Proceed as follows for decalcifying:

Procedure

1. Remove the water overflow hose from the vessel jacket and completely empty the vessel jacket.
2. Fit the piece of hose to with the funnel to the water overflow connection of the vessel jacket.
3. Fill the prepared decalcifying liquid into the vessel jacket.
4. Remove the piece of hose and funnel from the vessel jacket and refit the water overflow hose.
5. Connect the vessel to the basic unit.
6. Completely fill the vessel jacket with water.
7. Heat the vessel at a temperature of 50 °C for an hour.
8. Decrease the temperature and thoroughly rinse the jacket with cooling water.

Interferences

11 Interferences

The following section describes possible reasons for interferences and how to resolve them. Reduce the service intervals in correspondence with the actual loads if interferences become increasingly common. Contact the manufacturer or licensed dealer for interferences that cannot be resolved by following the above instructions.

11.1 Interferences Basic Unit and Operating Panel

Interference		
Device does not work. Power switch is not illuminated; screen of the operating panel remains dark.		
Possible cause	Remedy	By
Device is not switched on.	Switch on the device at the power switch.	Operator
Power supply of the device is interrupted.	<ul style="list-style-type: none"> ■ Check if the plugs are connected ■ Check the mains connection. 	Operator
Device fuse is blown.	Replace the fuse. If the fault occurs more than once, contact the INFORS HT representative.	Operator

Interference		
Power switch is illuminated; screen of the operating panel remains dark.		
Possible cause	Remedy	By
Monitor of operating panel is switched off.	Press the ON/OFF key on the monitor.	Operator
Power supply cable of the operating panel is not connected.	Connect the power supply cable to the DC connection of the operating panel.	Operator

Interference		
No communication between device and operating panel.		
Possible cause	Remedy	By
Display cable is not connected.	Connect the display cable: Plug the round connector in at the COM1 connection of the operating panel. Plug the flat connector in one of the two iDDC-bus connections on the rear side of the basic unit.	Operator

11.2 Interferences Drive System

Interference		
Stirrer does not start		
Possible cause	Remedy	By
The <i>Stirrer</i> parameter is not activated.	Activate the parameter.	Operator
<i>Stirrer</i> parameter setpoint = 0.	Set setpoint > 0.	Operator
The pO_2 parameter is activated and set to oxygen control via the stirrer (cascade).	Switch cascade off and test function via the <i>Stirrer</i> parameter.	Operator

Interference		
Motor (closed-loop) control is volatile, irregular or stops.		
Possible cause	Remedy	By
Incorrect PID settings in <i>Stirrer</i> parameter.	Reset the PID settings to default values.	Operator
Too much resistance due to very viscous medium.	Choose a lower stirrer speed. Dilute the medium.	Operator
The motor has overheated.	Let it cool down before restarting. If the motor does not start after cooling down, contact INFORS HT representative.	Operator

Interference		
Unusual sounds when the stirrer is switched on.		
Possible cause	Remedy	By
The stirrer touches other installed components in the culture vessel.	Stop the bioreactor. Shut down the system and switch off the device. Correctly mount installed parts under consideration of internal safety regulations.	Operator

Interferences

11.3 Interferences Temperature Control System

Interferences		
No temperature control.		
Possible cause	Remedy	By
Temperature control is not activated.	Switch parameter <i>Temperature</i> on.	Operator
Stirrer is not activated and/or set-point = 0.	Switch parameter <i>Stirrer</i> on and enter setpoint > 0, as required.	Operator

Interference		
No heating or inadequate heating.		
Possible cause	Remedy	By
Circulation not filled or air bubbles in circulation are obstructing the circulation flow	Enter low setpoint for parameter temperature to open the cooling valve and to fill the circulation (check acoustically) then enter a higher setpoint to heat up. Fully open the water supply for a moment. Check whether there is sufficient primary pressure on the water supply, adjust as necessary.	Operator
Cooling valve is blocked	Decalcify the equipment	Operator

Interference		
No cooling or inadequate cooling.		
Possible cause	Remedy	By
No water supply or inadequate flow.	Check the water supply and turn the supply tap if necessary.	Operator
Temperature sensor is not inserted.	Insert the temperature sensor into the immersion pocket in the vessel top plate.	Operator
Incorrect Negative factor in option <i>PID</i> of parameter <i>Temperature</i>	Check Negative factor: Value must be positive. Adjust as necessary.	Operator

Interference		
Temperature fluctuations		
Possible cause	Remedy	By
Incorrect PID settings parameter <i>Temperature</i>	Check PID settings and adjust as necessary, especially <i>P-term</i> .	Operator

11.4 Interferences Gassing System

Interferences		
No gassing / air bubbles in the culture vessel.		

Interferences

Possible cause	Remedy	By
The on-site gas supply has been interrupted.	Stop the bioreactor. Check the on-site gas supply and switch it on, if necessary.	Operator
Depending on the configuration of the gassing system: The rotameter valve(s) is/are not open. And/or: The <i>Flow</i> parameter(s) is/are not activated. And/or: Setpoint in the <i>Flow</i> parameter(s) = 0. Or: Parameter <i>GMFlow</i> = 0 and/or <i>GasMix</i> is/are not activated.	Slowly open the rotameter needle valve(s). And/or: Activate the <i>Flow</i> parameter(s). And/or: Set the setpoint(s) in the <i>Flow</i> parameter(s) > 0. Or: Set parameter <i>GMFlow</i> > 0 and activate parameter- <i>GasMix</i> .	Operator
Hose connection(s) between the basic unit and the culture vessel is/are kinked or clamped.	Check whether the hose connection(s) is/are clamped; if necessary open the clamp(s). Check hose connection(s) for kinks, if necessary route them again or replace them under observation of the sterility requirements.	Operator
Inlet air filter blocked.	Replace the inlet air filter under sterile conditions.	Operator

Interference

The desired gas flow rate is not reached.

Possible cause	Remedy	By
Blocked holes on the sparger.	Stop the bioreactor and clean the sparger.	Operator
The sparger is not or not completely extended.	Extend the sparger.	Operator

Interferences

Interference		
Sudden increase in evaporation losses in the culture vessel.		
Possible cause	Remedy	By
The exit gas cooler does not cool. The valve for water flow is closed.	Open the valve.	Operator
The exit gas cooler does not cool, parameter <i>Temperature</i> is activated.	Check the water supply to the exit gas cooler. Restore it, if necessary. The basic unit is calcified. Decalcify the equipment, if necessary.	Operator

11.5 Interferences pH-System

Interference		
No display or incorrect display of pH, digital measurement systems: the message ERROR is displayed instead of the current value.		
Possible cause	Remedy	By
Sensor cable not connected or not properly connected.	Connect properly if necessary.	Operator
<u>Analogue measurement system:</u> <i>Temp. Compens.</i> (temperature compensation) is switched off.	Switch the function <i>Temp. Compens</i> on in Setpoint option of parameter <i>pH</i> .	Operator
pH drift during long cultivation.	Recalibrate pH with external measured values, respectively perform a product calibration.	Operator
Faulty pH sensor.	Test calibration with pH 4 and pH 7 buffer. <u>Digital measurement systems:</u> Note the error message(s) (<i>Show Sensor Status</i>) when calling up the calibration menu. Regenerate or replace the sensor. Consult the documentation of the sensor manufacturer!	Operator

Interferences

Interference		
No pH control.		
Possible cause	Remedy	By
Parameter <i>pH</i> is not activated.	Activate the parameter.	Operator
Incorrect dead band setting.	Check the dead band (Dead Band in PID settings): Switch off or enter a small value.	Operator
No addition of reagents (acids and base).	Check the reagent bottles: Refill if necessary. Check the hose connections between the reagent bottles and the culture vessel: Connect properly if necessary. Open/remove hose clamps if necessary.	Operator
Pump(s) (base/acid) do/does not operate properly.	Check operation using the rocker switch.	Operator
Pump hose is damaged.	Replace pump head.	Operator
Incorrect hose type connected.	Replace if necessary.	Operator

Interference		
pH value drifts up and down over time or acid and base are added almost continuously in turn.		
Possible cause	Remedy	By
Incorrect PID setting in <i>pH</i> parameter.	Check the PID settings and adjust as necessary. Change the special proportional factor (<i>Prop. Term</i>) or <i>Dead band</i> setting.	Operator
Incorrect strength of reagents: Concentration is too weak or too strong.	Check the strength of reagents. Adjust if necessary: 0.1 mol to 2.0 mol.	Operator

Interferences

11.6 Interferences pO₂ System

Interferences		
No display or incorrect display of pO ₂ . Digital measurement systems: the message <i>ERROR</i> is displayed instead of the current value.		
Possible cause	Remedy	By
Sensor cable is not connected or not properly connected.	Connect the sensor cable properly.	Operator
<u>Analogue measurement system:</u> pO ₂ sensor is not polarised.	Polarise the pO ₂ sensor	Operator
Faulty pO ₂ sensor.	Check the calibration of the pO ₂ sensor. <u>Digital measurement systems:</u> Note the error message(s) (<i>Show Sensor Status</i>) when calling up the calibration menu. Replace the sensor if necessary. Consult the documentation of the sensor manufacturer!	Operator

Interference		
No pO ₂ control.		
Possible cause	Remedy	By
The pO ₂ parameter and/or cascaded parameter is/are not activated.	Activate parameters.	Operator
The cascade settings are incorrect.	Check the cascade settings and change as necessary.	Operator.
No gas flow into culture vessel.	Refer to interferences in the gassing system.	Operator

Interference		
Unstable pO ₂ control.		
Possible cause	Remedy	By
Incorrect PID settings in the pO ₂ parameter.	Check the PID settings (<i>PID</i> parameter option) and adjust as necessary. Special proportional factor (<i>Prop. Term</i>) and dead band. Dead band value must be 0 (zero).	Operator

11.7 Interferences Feed and Pump

Interference		
No addition of nutrient solution ("Feed") or inadequate addition.		
Possible cause	Remedy	By
Parameter <i>Feed</i> is not activated.	Activate the parameter.	Operator
Setpoint of parameter <i>Feed</i> = 0.	Set setpoint > 0.	Operator
Reagent bottle is empty.	Refill if necessary.	Operator
Hose line blocked or clamped.	Check the hose connection between the reagent bottle and the culture vessel: If necessary, connect them correctly. Open/remove clamp if necessary.	Operator
Feed pump does not work.	Check operation using the rocker switch.	Operator
The pump hose is damaged.	Replace pump head.	Operator
Incorrect hose type connected.	Replace if necessary.	Operator

11.8 Replacing Device Fuses



INFORMATION

Device fuses may only be replaced by fuses of the same rating. For detailed information concerning the requirements for the fuses refer to main chapter "Technical Data", chapter "Connection Values", "Electrical".

To replace a defective device fuse, proceed as follows:

Procedure

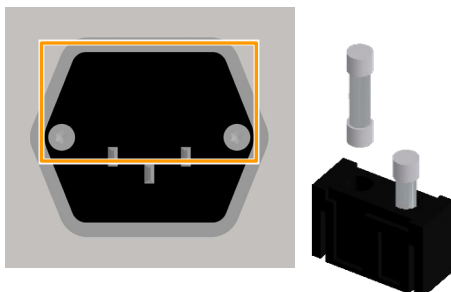

1. Switch off the device and pull out the power plug.
2. Unlock the plug for the fuses by pressing together the two flaps and pull out the plug at the same time.
3. Remove the defective fuse.
4. Insert a new fuse with the correct number of Amperes.
5. Push the plug as far back in the opening as possible until it snaps in.
6. Re-establish the power supply to the device.

Interferences

11.9 Behaviour in Case of Power Interruption

If the power supply to the device is interrupted during a running cultivation process (e.g. by turning off at the power switch or in case of a power failure), all parameter setpoints are stored.

After the power supply is restored, an interrupted cultivation process is automatically continued with the last stored setpoints.

The fact that a power interruption has occurred is indicated by the system alarm *Restart after power failure*. However, the duration of the event cannot be determined from the alarm.

11.10 Returning for Repair

The provider must return the device or the faulty component part(s) to the manufacturer if, after consulting the service department of the local dealer or the manufacturer, on-site diagnosis and/or repair is not possible.



INFORMATION

When returning the device, the component part or accessory for repair, it is required for the safety of all parties involved and because of legal provisions that a lawful declaration of decontamination is present. Refer to main chapter “Safety and Responsibility”, chapter “Declaration of Contamination” for details.

12 Disassembly and Disposal

The device must be disassembled and disposed of in an environmentally friendly manner if it is no longer in use.



INFORMATION

When returning the device for disassembly or disposal, it is required for the safety of all parties involved and because of legal provisions that a lawful declaration of decontamination is present. Refer to main chapter "Safety and Responsibility", chapter "Declaration of Contamination" for details.

12.1 Disassembly

Prior to disassembly:

- Switch off the device and lock any isolation switch in the 'off' position.
- Physically disconnect the main energy supply from the device and wait for components to fully discharge.
- Remove and dispose of all additional consumable items, auxiliary components and/or spent processing material in an environmentally acceptable manner.

Clean and disassemble component parts professionally with regard to any local regulations concerning employment and environmental protection. If possible, separate materials.

Disassembly and Disposal

12.2 Disposal

Recycle disassembled components if no agreement is made concerning reclaim or disposal.

- Send metals for scrap.
- Send plastic components for recycling.
- Sort and dispose of the remaining components according their material composition.



WARNING

Electronic waste, electronic components, lubricants or other auxiliary materials/supplies are subject to hazardous waste regulations and may only be disposed of by registered specialist disposal firms.

For disposal, the system units are to be disassembled and dismantled into individual material groups. These materials are to be disposed of according to the applicable national and local legislation.

Local authorities or specialist disposal firms can provide information regarding environmentally acceptable disposal.

If no special arrangements have been made for return, INFORS HT units with the required declaration of decontamination can be sent back to the manufacturer for disposal.

13 Technical Data

13.1 Dimensions 1 Unit

Front view

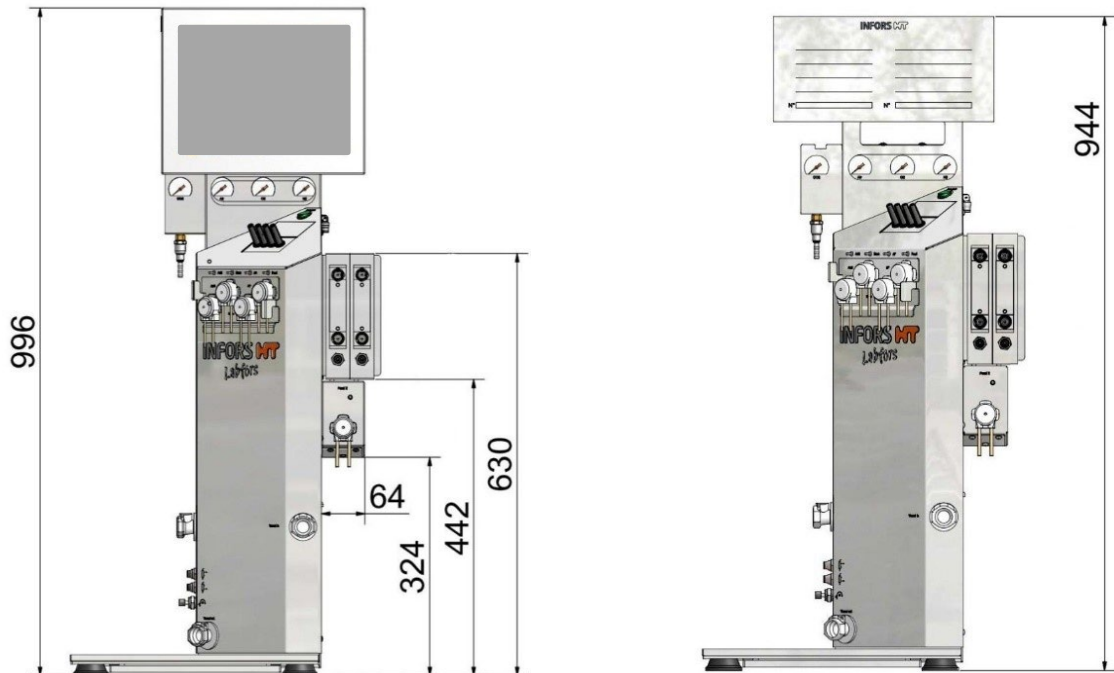

Dimensions in mm

- To the left: device with operating panel, holder for up to 2 gassing units, 5 pumps, and standard base tray
- To the right: satellite unit, holder for up to 2 gassing units, 5 pumps and standard base tray

Technical Data

Top view and side view

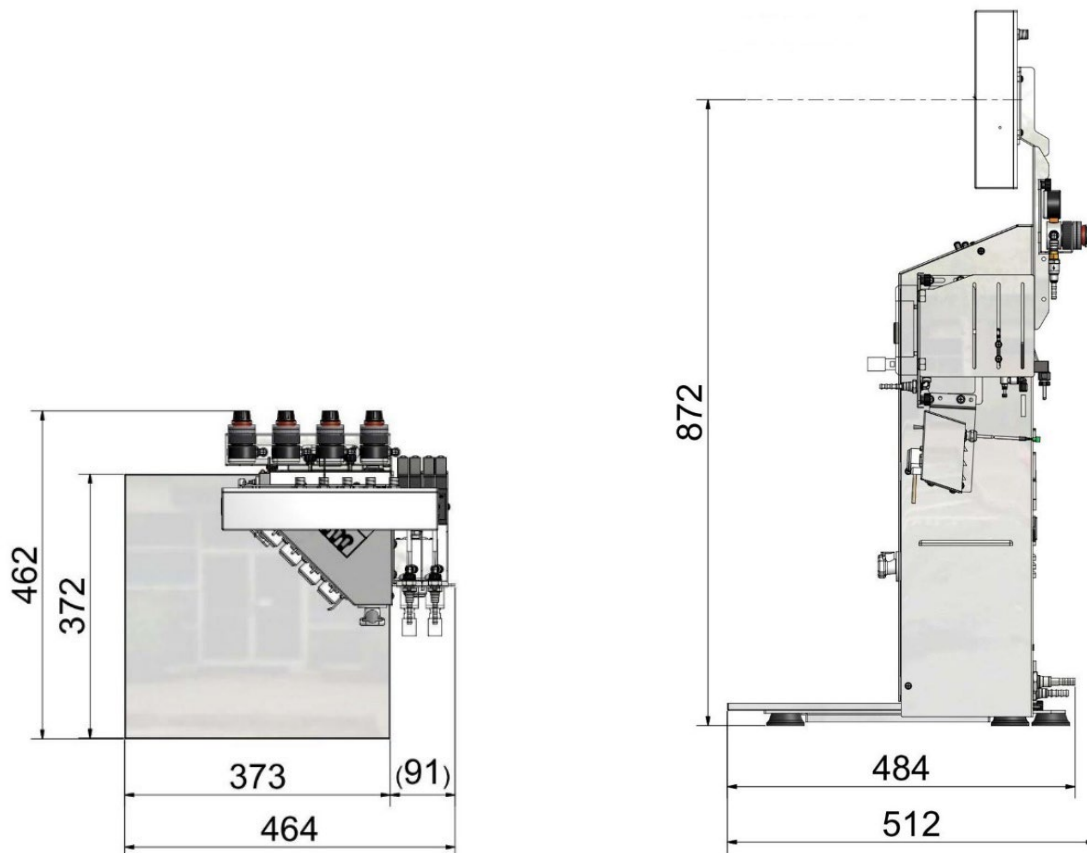

Dimensions in mm

- To the left: device with holder for up to 2 gas-sing units and standard base tray
- To the right: device with operating panel and standard base tray

13.2 Dimensions Master Unit and Satellite Units

Front view master unit with 5 satellite units

(with holder for up to 4 gassing units, 5 pumps and standard base tray)

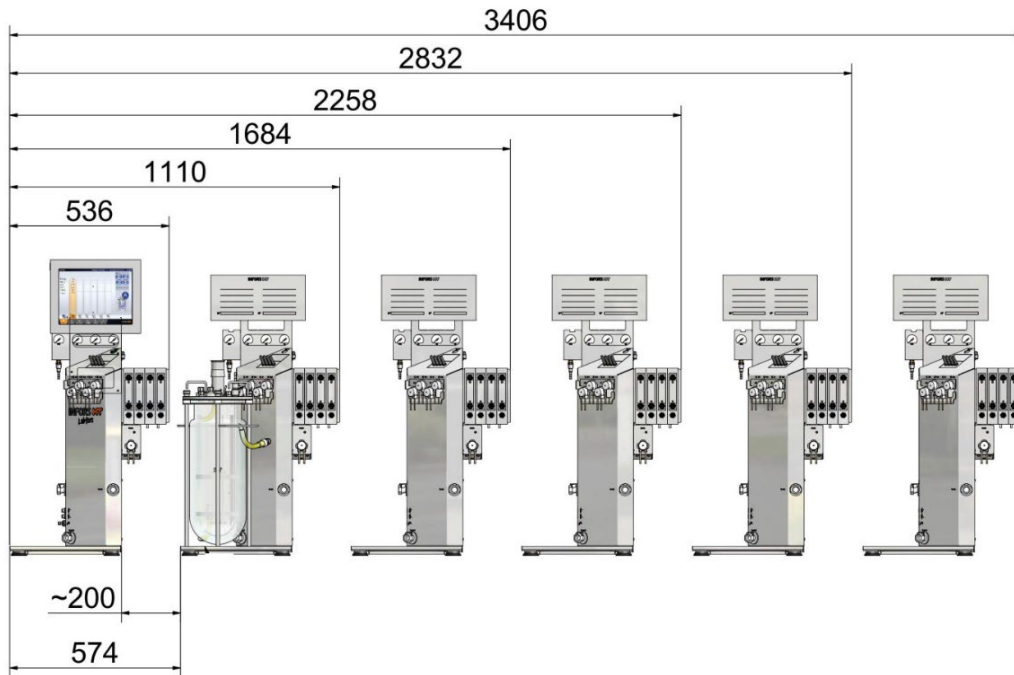

Dimensions in mm

Technical Data

13.3 Dimensions of Culture Vessels in Vessel Holder

Top view

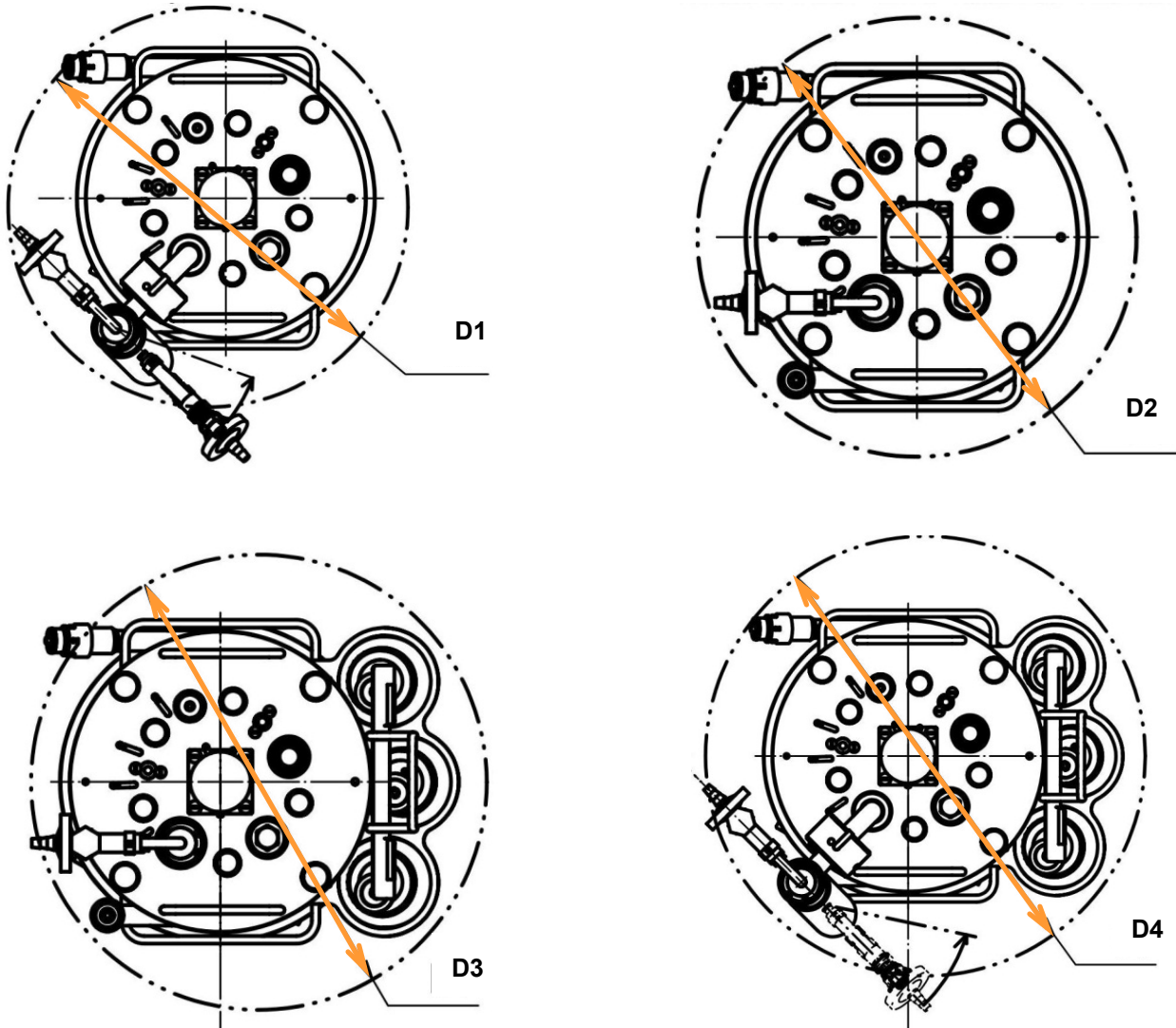

By way of an example, the figures above show top view of the culture vessel with standard exit gas cooler and with swivelling exit gas cooler and, with / without reagent bottle und pump holder.

- Ø D1: 335 mm
- Ø D2: 320 mm
- Ø D3: 355 mm
- Ø D4: 380 mm

Side view

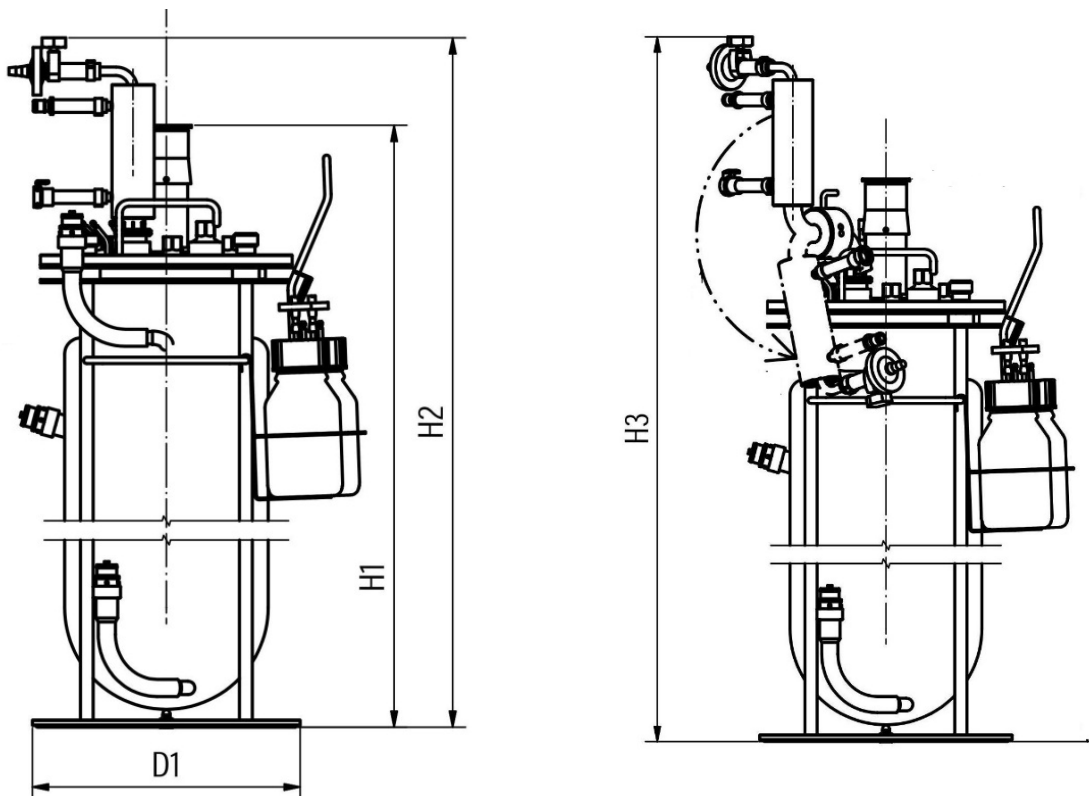

By way of an example, the figures show the culture vessel with standard exit gas cooler (left) and with swivelling exit gas cooler (right), both with reagent bottle and pump holder.

- D1: 250 mm
- H1: 405 mm
- H2: 487 mm
- H3: 546 mm

Technical Data

13.4 Weights (net)

Description	Value	Unit
Basic unit	25	kg
Touch screen operating unit	5	kg

Culture vessel

Total volume L	Diameter nominal mm	Weight kg ¹⁾
3.6	150	15

¹⁾ Empty weight of double walled culture vessels in delivery state (equipped with default mounting parts)

13.5 Connection Values

13.5.1 Electrical

Description	Type 230 V	Type 115 V	Unit
	Value		
Voltage	230	115	V
Frequency range	50 / 60	60	Hz
Max. current	4	8	A
Fuses (5 x 20 mm, slow-blown)	4	8	A

13.5.2 Water IN

Description	Value	Unit
Connection pressure	2 ± 1	bar
Inlet temperature	10 to 20	°C
Connection: OD of hose nozzle	8.3	mm
Max. flow cooling vessel	1.6	L min ⁻¹
Max. flow cooling exit gas cooler	1.6	L min ⁻¹
Water quality	„Very soft“ / „soft“ (CaCO ₃ concentration 0 mmol L ⁻¹ to 1.5 mmol L ⁻¹)	

 INFORMATION

The heating system has protection against dry running, which is based on measurement of conductivity. The heating will not work when using demineralised or distilled water as cooling agent!

13.5.3 Water OUT

Description	Value	Unit
Connection pressure	No back pressure	
Temperature	up to 80	°C
Connection: Outside diameter hose nozzle	10	mm

13.5.4 Gas(es) IN

Description	Value	Unit
Connection pressure	2 ± 0.5	bar
Connection: outside diameter of hose nozzle	7	mm
General gas quality	Dry, clean and free of oil and dust	
Recommended compressed air quality	Class 1,2,3,4 As per DIN ISO 8573-1	

13.5.5 Exit Gas

Description	Value	Unit
Connection pressure	No back pressure	
Connection: outside diameter of hose nozzle	8	mm

Technical Data

13.6 Specifications

13.6.1 Operating Panel

Description	Value
HMI	Colour touch screen 12"
Protection	IP 66

13.6.2 Culture Vessel

General	
Form	Cylindrical with flat bottom
Model	Double walled (vessel jacket)
Material glass vessel	Borosilicate glass
Material top plate and built-in-parts	AISI 316L, electropolished
Material O-rings (in contact with product)	EPDM

Vessel size	
Total volume	3.6 L
Max. working volume	2.5 L
Min. working volume	1.0 L
Nominal diameter = inside diameter vessel	150 mm
Height	220 mm
Weight (empty culture vessel with standard equipment)	15 kg

Ports in vessel top plate		
Diameter	Thread	Number
10 mm	None	2
12 mm	Pg13,5	3
19 mm	None	4
40 mm	None	1

13.6.3 Stirrer

Drive and range of rotation speed

Description	Value
Drive	Shaft with mechanical seal
Motor	Type: DC, brushless Nominal power: 140 W Nominale torque: 2.8 Nm
Transmission	3 : 1
Nominal torque	3 Nm ¹⁾
Range of rotation speed	10 to 1000 min ⁻¹ ²⁾
Accuracy measurement / control	≤ ± 5 min ⁻¹
Direction of rotation	Counter clockwise (top view vessel)
Bearing	Outside of vessel, in drive hub

1) *Viscosity ≤ Glycerine at 37 °C.*

2) *Medium liquid and homogen, viscosity ≤ Glycerine at 37 °C, no solids in medium which could block the impellers.*

Impellers

All the impellers are made of 316L stainless steel, electro polished and are included in the standard package.

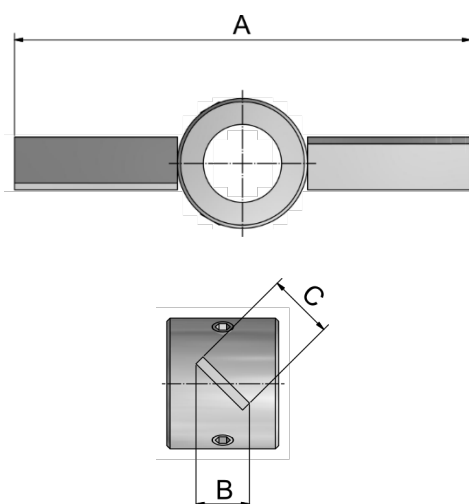

Angle-bladed impeller

Position	Dimension
A	70 mm
B	8 mm
C	10 mm

Technical Data

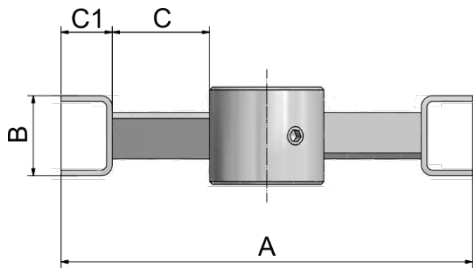

Fork impeller

Position	Dimension
A	72 mm
B	14 mm
C	17 mm
C1	9 mm
D	10 mm

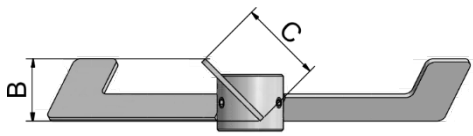
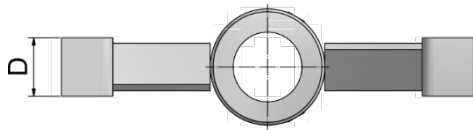

Anchor impeller

Position	Dimension
Ø A	140 mm
B	19 mm
C	25 mm

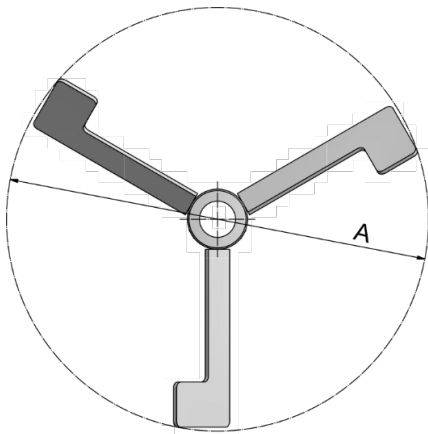

Single helix impeller

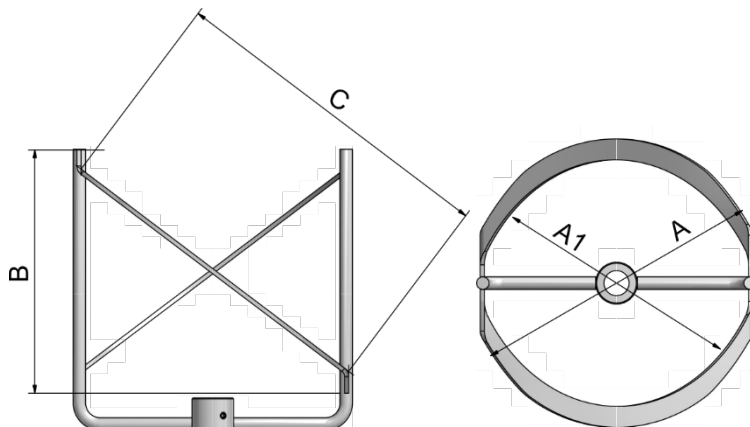

Position	Dimension
Ø A	140 mm
Ø A1	118 mm
B	117 mm
C	161 mm

Double helix impeller

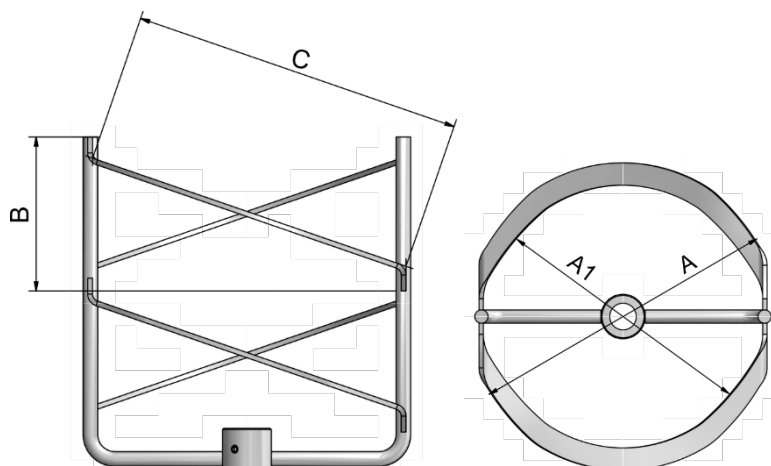

Position	Dimension
Ø A	140 mm
Ø A1	118 mm
B	63 mm
C	136 mm

Technical Data

13.6.4 Temperature Control System

Description	Value
Heating	Water circulation in vessel jacket. Pump and heating 500 W integrated in basic unit.
Cooling	With tap water via water circuit into vessel jacket Option: with circulation chiller
Sensor	Type: Pt100 1/3 DIN-B
Range of measurement	0 °C to +145 °C
Range of control	from 5 °C above inlet temperature up to 70°C
Accuracy measurement and control	At ≤ 60 °C: ± 0.3 °C At > 60 °C: ± 0.5 °C

13.6.5 Gassing

General	
Gas entry	Sparger or head space
Specific gassing rate	2 min ⁻¹ (calculated for max. working volum vessel)
Gas(es)	Air, N ₂

Gassing with rotameter	
Gas flow control	Rotameter
Accuracy rotameter	± 5 %
Measurement range air and N ₂	0.3 L min ⁻¹ to 4.7 L min ⁻¹

Gassing with mass flow controller (MFC)	
Gas flow control	MFC, 1 per gas
Accuracy measurement	± 1.5 % FS
Accuracy control	≤ ± 1.5 % FS
Measurement range air and N ₂	0.05 L min ⁻¹ to 5 L min ⁻¹

i INFORMATION

The mass flow controllers are calibrated by their manufacturer ex works at standard conditions, i.e. at 1.013 bar and 20 °C. Therefore, for every gas flow rate the gas volume flow is given in L min⁻¹.

13.6.6 Antifoam Control

Description	Value
Sensor	Conductive with dosing needle, adjustable mounting depth
Control	Peristaltic pump <i>Antifoam</i>
Range	0 % (no foam) / 100 % (foam)

13.6.7 pH Control

Description	Value
Control	Peristaltic pumps <i>Acid</i> and <i>Base</i>
Control range	pH 2 to 12
Measurement accuracy	pH ± 0.1

Variants of measurement systems

Measurement system analogue

Traditional pH sensor (potential measurement against reference)

Variant METTLER	Sensor type	405-DPAS-SC-K8S/120
	Measurement range	pH 2 to 12

Measurement systems digital

Traditional pH sensor (potential measurement against reference) with integrated electronics

Variant HAMILTON	Sensor type	Easyferm Plus ARC
	Measurement range	pH 0 to 14
Variant METTLER	Sensor type	InPro 3253i, ISM
	Measurement range	pH 0 to 12

i INFORMATION

pH sensors type Easyferm Plus ARC are preconfigured by the device manufacturer INFORS HT. Replacement sensors must be configured before use.

Technical Data

Details about technical data, use and maintenance of the pH sensors are in the separate documentation from the sensor manufacturers.

13.6.8 pO₂ Control

Description	Value
Control	Via cascade: Stirrer, gas flow, gasmix, O ₂ addition. <i>The functionality of the parameters depends on the hardware configuration of the device.</i>
Control range	0 %-sat to 100 %-sat
Measurement accuracy	1 % FS

Variants of measurement systems

Measurement system analogue		
Traditional amperometric/polarographic pO ₂ sensor		
Variant METTLER	Sensor type	InPro 6820/25/080
	Measurement range	0 % sat to 150 %-sat
Measurement systems digital		
pO ₂ sensor with integrated optical electronics		
Variant HAMILTON	Sensor type	Visiform RS485-ECS
	Measurement range	0 %-sat to 300 %-sat
Variant METTLER	Sensor type	InPro6860i, ISM
	Allowed temperature range	0 °C to 60 °C
	Measurement range	0 %-sat to 285 %-sat



INFORMATION

Digital pO₂ sensors are pre-configured from the device manufacturer INFORS HT. Replaced sensors must be configured again before use!

Details about technical data, use and maintenance of the pO₂ sensors are in the separate documentation from the sensor manufacturers.

Technical Data
13.6.9 Pumps

Description	Value	
Type	Peristaltic	
Standard	Digital	Acid Base Antifoam
	Analogue	Feed
Rotation speed	Digital	74 min ⁻¹ / fixed rotation speed
	Analogue	74 min ⁻¹ / max. rotation speed, adjustable within range of 0 % to 100 % (increment 0.1 %)
Accuracy	± 1 % FS	

Pump hoses and flow rates

Description	Value
Material	PharMed BPT
Standard	iD: 1.0 mm Wall thickness: 1.1 mm Flow rate: 3.5 mL min ⁻¹
Option 1	iD: 0.5 mm Wall thickness: 1.15 mm Flow rate: 1.2 mL min ⁻¹
Option 2	iD: 2.5 mm Wall thickness: 1,0 mm Flow rate: 16.1 mL min ⁻¹
Flow rates	All flow rates at 74 min ⁻¹ (100 % rotation speed)

13.7 Operating Conditions

Description	Value
Ambient temperature	5 °C up to 40 °C
Relative air humidity, non-condensing	20 % up to 90 %
Altitude operating location	max. 2000 m.a.s.l
Degree of pollution (as per EN 61010-1)	2
Min. distance from walls, ceilings and other appliances	150 mm

Technical Data

13.8 Emissions

Description	Value	Units
Noise emission	<70	dB (A)

13.9 Utilities

Glycerine

Lubricant for mechanical seal.

Permitted product:

- Medicinal Glycerine 85 %
- Quality: PhEur

13.10 Auxiliary Supplies

pH Buffers

pH buffers are used to calibrate the pH sensors. 250 mL bags are available for the following buffers:

- pH 4.04
- pH 7.01

14 EC-Declaration of Conformity

EG-Konformitätserklärung

EC-Declaration of conformity

Déclaration CE de conformité



Infors AG, Headoffice, Switzerland
Rittergasse 27, CH-4103 Bottmingen
T +41 (0)61 425 77 00
info@infors-ht.com, www.infors-ht.com

Gemäss der EG-Maschinen-Richtlinie 2006/42/EG, Anhang II 1 A

In accordance with directive on machinery 2006/42/EC, appendix II 1 A

D'après la directive relative aux machines 2006/42/CE 2006, annexe II 1 A

Hersteller <i>Manufacturer</i> <i>Fabricant</i>	Infors AG Rittergasse 27 CH-4103 Bottmingen
Bezeichnung <i>Designation</i> <i>Désignation</i>	Tischbioreaktor Bench-top bioreactor Bioréacteur de paillasse
Typ <i>Type</i> <i>Type</i>	Labfors 5
Ab Release <i>From release</i> <i>A partir du version</i>	alle Releases all releases toutes les versions
Ab Seriennummer <i>From serial number</i> <i>A partir du numéro de série</i>	S-000127197

Dieses Gerät entspricht den grundlegenden Anforderungen der Richtlinien

This device is in compliance with the essential requirements of directives

Cet appareil est conforme aux exigences essentielles des directives

Maschinenrichtlinie 2006/42/EG	<i>Directive on machinery 2006/42/EC</i>	<i>Directive relative aux machines 2006/42/CE</i>
EMV-Richtlinie 2014/30/EU	<i>EMC directive 2014/30/EU</i>	<i>Directive CEM 2014/30/UE</i>

Aussteller Bevollmächtigter für die technische Dokumentation
Issuer *Person authorised to compile the technical file*
Editeur *Person autorisée à constituer le dossier technique*

C. Rutishauser

Infors AG
Rittergasse 27
CH-4103 Bottmingen

Anschrift
Address
Adresse

Konformitätsbeauftragter
Representative for conformity
Responsable de la conformité

M. Heuschkel
Chief Technology Officer

Bottmingen, 16. Nov. 2021

Ort, Datum
Place, date
Lieu, date

